

**JR**  
*feel the difference!*

INSTRUCTION MANUAL FOR  
AIRPLANE AND HELICOPTER



# ***XP6102***

**6-CHANNEL COMPUTER RADIO SYSTEM**

---

# TABLE OF CONTENTS

## TABLE OF CONTENTS

TABLE OF CONTENTS .....	2	CHAPTER 1: SOFTWARE FUNCTIONS – AIRPLANE .....	11
CHAPTER 1: USING THIS MANUAL • INTRODUCTION .....	6	Transmitter Callouts .....	12
Using this Manual .....	6	Transmitter Rear .....	13
R770 Receiver .....	6	Direct Servo Control (DSC) .....	14
CHAPTER 2: FEATURES .....	6	Control Stick Tension Adjustment ..	14
X-6102 Transmitter .....	6	Control Stick Length Adjustment ..	14
Transmitter Specifications .....	7	Frequency Notes/ Aircraft Only Frequencies .....	15
System Specifications .....	7	Base Loaded Antenna .....	15
CHAPTER 3: COMPONENT SPECIFICATIONS .....	7	Neck Strap Attachment .....	15
S537 Ball Bearing Servo .....	7	CHAPTER 2: CONNECTIONS • AIRPLANE .....	16
Airborne Battery Pack .....	8	Installation Requirements .....	16
Charger Specifications .....	8	Connections .....	17
Receiver Specifications .....	8	Backup Error Display .....	18
Servo Specifications .....	8	CHAPTER 3: INPUT MODE AND FUNCTION • AIRPLANE ....	18
Charger .....	9	Key Input and Display .....	18
Transmitter/Receiver .....	9	System Mode .....	19
CHAPTER 4: BATTERY CHARGING .....	9	Normal Mode .....	19
Advanced Digital Trims .....	10	CHAPTER 4: ALARM AND ERROR DISPLAY • AIRPLANE .....	18
SECTION II • AIRCRAFT .....	11	Battery Alarm and Display .....	18
Channel Assignment/ Throttle Alt .....	11		
Control Identification and Location .....	11		

**CHAPTER 5: SYSTEM MODE •  
AIRPLANE .....19**

**Wing Type Selection .....20**  
 Definition of Wing Types .....20

**Flaperon Wing Type Selection ....21**  
 Accessing and Utilizing the  
 Flaperon Wing Type Selection ..21

**Elevon Type Selection .....22**  
 Accessing and Utilizing  
 the Elevon Type Selection .....22

**V-Tail Type Selection .....23**  
 Accessing and Utilizing  
 the V-Tail Type Selection .....23

Accessing the  
 Modulation Function .....24

**Switch Select .....24**

**Trainer Function .....25**  
 Accessing the  
 Trainer Function .....25

**Modulation Selection .....26**  
 Accessing the  
 Modulation Function .....26

**Model Copy Function .....27**  
 Accessing the  
 Model Copy Function .....27

**Model Type Selection .....28**  
 Accessing the  
 Type Selection Function .....28

**Model Name Entry .....29**  
 Accessing the Model  
 Name Entry Function .....29

**Model Selection .....30**  
 Accessing the  
 Model Select Function .....30

**Function Mode .....31**  
 Accessing the  
 Mode Function .....31

**CHAPTER 6: FUNCTIONS (FUNCTION MODE)  
• AIRPLANE .....31**

**Dual Rates and Exponential .....32**  
 Accessing the Dual-Rate  
 and Exponential Function .....32

**Servo Reversing .....33**  
 Accessing the  
 Servo Reversing Function .....33

**Sub Trim .....34**  
 Accessing the  
 Sub Trim Function .....34

**Travel Adjust .....35**  
 Accessing the  
 Travel Adjust Function .....35

**Elevator to Flap Mixing .....36**  
 Accessing the  
 Elevator to Flap Function .....36

**Aileron to Rudder Mixing .....37**  
 Accessing the Aileron  
 to Rudder Mixing Function .....37

**Throttle Cut Switch .....38**  
 Accessing the  
 Throttle Cut Function .....38

**Flap System .....39**  
 Accessing the  
 Flap System Function .....39

**Programmable Mixing (1-4) .....40**  
 Accessing the Programmable  
 Mixing Function .....41

**Fail Safe .....42**  
 Accessing the  
 Fail Safe Function .....42

**Servo Travel Screen .....43**  
 Accessing the  
 Servo Travel Screen .....43

**XP6102 Data Sheet .....44**

# TABLE OF CONTENTS

<b>SECTION III • HELICOPTER</b> .....	<b>45</b>	<b>CHAPTER 11: SYSTEM MODE •</b>	<b>53</b>
Channel Assignment/ Throttle Alt .....	45	<b>HELICOPTER</b> .....	<b>53</b>
Control Identification and Location .....	45	<b>Model Selection</b> .....	<b>54</b>
<b>CHAPTER 7: SOFTWARE FUNCTIONS –</b>	<b>45</b>	Accessing the Model	
<b>HELICOPTER</b> .....	<b>45</b>	Select Function .....	54
Transmitter Callouts .....	46	<b>Swashplate Type Selection</b> .....	<b>55</b>
Transmitter Rear .....	47	Definition of	
Direct Servo Control (DSC) .....	48	Swashplate Types .....	55
Control Stick Tension Adjustment ..	48	<b>Switch Select</b> .....	<b>56</b>
Control Stick Length Adjustment ..	48	<b>Trainer Function</b> .....	<b>57</b>
Frequency Notes/Aircraft		Accessing the	
Only Frequencies .....	49	Trainer Function .....	57
Base Loaded Antenna .....	49	<b>Modulation Selection</b> .....	<b>58</b>
Neck Strap Attachment .....	49	Accessing the	
		Modulation Function .....	58
<b>CHAPTER 8: CONNECTIONS •</b>	<b>50</b>	<b>Model Copy Function</b> .....	<b>59</b>
<b>HELICOPTER</b> .....	<b>50</b>	Accessing the	
Installation Requirements .....	50	Model Copy Function .....	59
Connections .....	51	<b>Model Type Selection</b> .....	<b>60</b>
Backup Error Display .....	52	Accessing the	
<b>CHAPTER 9: INPUT MODE AND FUNCTION •</b>	<b>52</b>	Type Selection Function .....	60
<b>HELICOPTER</b> .....	<b>52</b>	<b>Model Name Entry</b> .....	<b>61</b>
Key Input and Display .....	52	Accessing the Model	
System Mode .....	53	Name Entry Function .....	61
Normal Mode .....	53	<b>Function Mode</b> .....	<b>63</b>
<b>CHAPTER 10: ALARM AND ERROR</b>		Accessing the	
<b>DISPLAY • HELICOPTER</b> 52		Mode Function .....	63
Battery Alarm and Display .....	52		

**CHAPTER 12: FUNCTIONS (FUNCTION MODE ) • HELICOPTER ..63**

**Dual Rates and Exponential .....64**  
 Accessing the Dual Rate and Exponential Function .....64

**Servo Reversing .....65**  
 Accessing the Servo Reversing Function .....65

**Sub Trim .....66**  
 Accessing the Sub Trim Function .....66

**Travel Adjust .....67**  
 Accessing the Travel Adjust Function .....67

**CCPM Swashplate Mixing .....68**  
 Accessing the Swashplate Type .....68

**Throttle Cut Switch .....70**  
 Accessing the Throttle Cut Function .....70

**Throttle Hold .....71**  
 Accessing the Throttle Hold Function .....71

**Throttle Curves .....72**  
 Throttle Time Settings .....73  
 Accessing the Throttle Curve Function .....73  
 Hovering Throttle Lever Settings .....74  
 Accessing the Pitch Curve Function .....75

**Pitch Curves .....75**  
 Hovering Pitch Lever .....76  
 Accessing the Revolution Mixing Function .....77

**Revolution Mixing (Non-Heading Lock Gyros Only) ..77**  
 Setting Up Revolution Mixing (non-heading lock gyros only) .....78

**Programmable Mixing (1-2) .....79**  
 Accessing the Programmable Mixing Function .....80

**Fail Safe .....81**  
 Accessing the Fail Safe Function .....81

**Servo Travel Screen .....82**  
 Accessing the Servo Travel Screen .....82

**XP6102 Data Sheet - Heli .....83**

**General Notes .....85**

**SECTION IV • IMPORTANT INFORMATION.....85**

**Servo Precautions .....85**

**Daily Flight Checks .....86**

**Federal Aviation Administration ..86**

**Frequency Chart .....87**

**Warranty Information .....88**

# CHAPTER 1: USING THIS MANUAL • INTRODUCTION

1

## USING THIS MANUAL

---

In the beginning of this manual you will find the specifications for the radio and its various accessories. In addition, guidelines for the installation have been included. Instructions for setting all the functions and programs of the X-6102 are also included. These features are discussed in the same order that they will appear in your radio, as you will see on the accompanying pages. An explanation of the use and purpose of each feature is provided, followed by a labeled illustration of its respective LCD display.

In addition, a step-by-step example clarifies the setup procedure for the feature.

A blank data sheet has been included at the end of each section. Once all data has been input for a particular model, it is highly recommended that you record it on a copy of the sheet provided. If you should experience memory loss or battery failure or want to make changes to the current settings, this step will save you a great deal of time.

## CHAPTER 2: FEATURES

---

2A

### X-6102 TRANSMITTER

---

The computer-designed, ergonomically-styled transmitter case ensures a comfortable fit in your hands. The ultra-precision control sticks offer adjustable spring tensions and length. The throttle stick offers a ratchet in Airplane configuration. 10-model memory storage allows programming of all parameters of ten separate helicopters or airplanes; you

can program more than one setup for a single aircraft, allowing you to instantly change the flight characteristics.

A five-year lithium backup battery prevents loss of memory in the event that the battery discharges completely or is removed.

2B

### R770 RECEIVER

---

#### **R770 (PCM Systems)**

The R770 is a high-performance PCM single-conversion receiver with 10KHz super narrow band ABC&W circuitry.

A narrow band ceramic filter for high-signal selectivity assists in rejecting cross modulations from other common radio frequencies, such as RC transmitters or local paging systems.

This receiver features Direct Servo Control (DSC) for control of servos without radio frequency output.

The receiver has low current consumption.

The R770's Slimline design allows it to fit into most model applications.

**537 Servo**

- Wide-spaced ball bearing support for precise movement of your aircraft control outputs
- A zero deadband amplifier ensures accurate neutral centering
- Low current drain
- Indirect drive feedback potentiometer gives additional protection from vibration
- 3-pole ferrite cored motor

**CHAPTER 3: COMPONENT SPECIFICATIONS**

**SYSTEM SPECIFICATIONS**

<u>TYPE</u>	<u>AIRPLANE</u>	<u>HELICOPTER</u>
SYSTEM NAME	X-6102A	X-6102H
TRANSMITTER BODY	NET-K236US	Net-K236US
RECEIVER	R700 (FM) or R770 (PCM)	R700 (FM) or R770 (PCM)
CHARGER	NEC-222	NEC-222
AIRBORNE BATTERY	1100mah	1100mah
SERVOS	NES-537X4	NES-537X5
ACCESSORIES	Standard Switch 12" Aileron Extension Charge Jack Servo Accessories Hex Wrench Instruction Manual	Standard Switch 12" Aileron Extension Charge Jack Servo Accessories Hex Wrench Instruction Manual

**TRANSMITTER SPECIFICATIONS**

<u>TYPE</u>	<u>AIRPLANE</u>	<u>HELICOPTER</u>
MODEL NUMBER	NET-K236US	NET-K236US
ENCODER	6-channel computer system	6-channel computer system
RF MODULE	72MHz	72MHz
MODULATION	PCM (s) or PPM	PCM (s) or PPM
OUTPUT POWER	Approximately 750mw	Approximately 750mw
CURRENT DRAIN	200mA (70mA with DSC)	200mA (70mA with DSC)
POWER SOURCE	1.2Vx Ni-Cd (9.6V) 600mAh	1.2Vx Ni-Cd (9.6V) 600mAh
OUTPUT PULSE	1000-2000 (1500 Neutral)	1000-2000 (1500 Neutral)

**3C****SERVO SPECIFICATIONS**

<b>TYPE</b>	<b>537</b>
TORQUE (ounce inch)	43 oz/in
SPEED (sec/60°)	.25
WEIGHT (oz)	1.58
SIZE (in) (L x W x H)	1.52 x 0.73 x 1.32
BB	Single
MOTOR	3-Pole Ferrite

**3D****RECEIVER SPECIFICATIONS**

TYPE	FM	PCM
MODEL NUMBER	R700	R770
TYPE	7-Channel / FM-ABC&W / Micro	7-Channel / FM-ABC&W / Micro
FREQUENCY	72MHz	72MHz
SENSITIVITY (Microseconds)	5 uS minimum	5 uS minimum
SELECTIVELY	8KHz/5 dB	8KHz/5 dB
WEIGHT (oz)	1.5	1.5
RECEIVER ANTENNA	39" for all aircraft frequencies	39" for all aircraft frequencies

**3E****CHARGER SPECIFICATIONS**

<b>TYPE</b>	<b>AIRCRAFT</b>	<b>HELICOPTER</b>
MODEL NUMBER	NEC-222	NEC-222
INPUT VOLTAGE	AC 100-120V	AC 100-120V
OUTPUT CURRENT	50mAh TX/120mAh RX	50mAh TX/120mAh RX
CHARGING TIME	15 Hours	15 Hours

**3F****AIRBORNE BATTERY PACK**

<b>TYPE</b>	<b>AIRCRAFT</b>	<b>HELICOPTER</b>
MODEL NUMBER	B1100	B1100
VOLTAGE	4.8 V	4.8 V
SIZE (in) (W x L x H)	2.24 x 0.63 x 1.70	2.24 x 0.63 x 1.70
WEIGHT (oz)	4.9	4.9

## TRANSMITTER/RECEIVER

4A

**Note:** It is imperative that you fully charge both the transmitter and the receiver battery packs prior to each trip to the field. To do so, leave the charger and batteries hooked up overnight (16 hours). The first charge should be approximately 20–24 hours in order to fully charge both battery packs to peak capacity.

The charger supplied with this system is designed to recharge your batteries at a rate of 50mAh for the transmitter and 120mAh for the receiver battery pack.

### Transmitter Only

The center pin on all JR® Remote Control Systems is negative. Therefore, the center pin on all JR chargers is negative, not positive. This is different from many other manufacturers' chargers and radio systems. Beware of improper connections based on "color-coded" wire leads, as they do not apply in this instance. You must make sure that the center pin of your JR transmitter is always connected to the negative voltage for correct polarity hookup.

**Important:** Please note that the charging polarity of the transmitter and receiver are different.

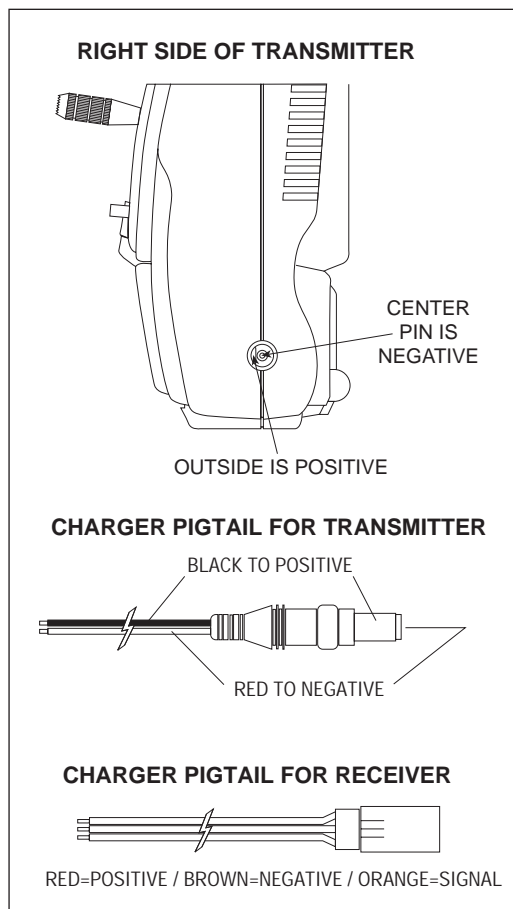

## CHARGER

4B

The pilot lamps should always be on during the charging operation. If not, check to make sure that both the transmitter and receiver are switched off.

Do not use the charger for equipment other than JR. The charging plug polarity may not be the same. Equipment damage can result.

Do not use other manufacturers' after-market accessories that plug into the transmitter's charging jack if you are unsure of compatibility issues with your radio. Seek expert advice to avoid possible damage.

During the charging operation, the charger's temperature is slightly elevated. This is normal.

The XP6102's digital trims feature the Direct Access display function. While at the Normal display screen, if a trim lever is moved, the screen will automatically change to display the graphic position for the trim being adjusted. The XP6102's Aileron, Elevator, Throttle and Rudder trim levers feature an audible center trim beep. This is helpful in determining the trim levers center position during flight.

Please also note that unlike conventional mechanical trim levers, when the X-6102 transmitter is in the off position, no changes can be made to the trim values during transportation.



### CHANNEL ASSIGNMENT/THROTTLE ALT

#### 1B

#### Channel TX Function Airplane Function

1	THRO	Throttle Channel
2	AILE	Aileron Channel
3	ELEV	Elevator Channel
4	RUDD	Rudder Channel
5	GEAR	Gear Channel
6	AUX 1	Auxiliary 1 Channel (Flap)

#### Throttle ALT

The Throttle ALT function makes the throttle stick trim active only when the throttle stick is at less than half throttle. This gives easy, accurate idle adjustments without affecting the high throttle position.



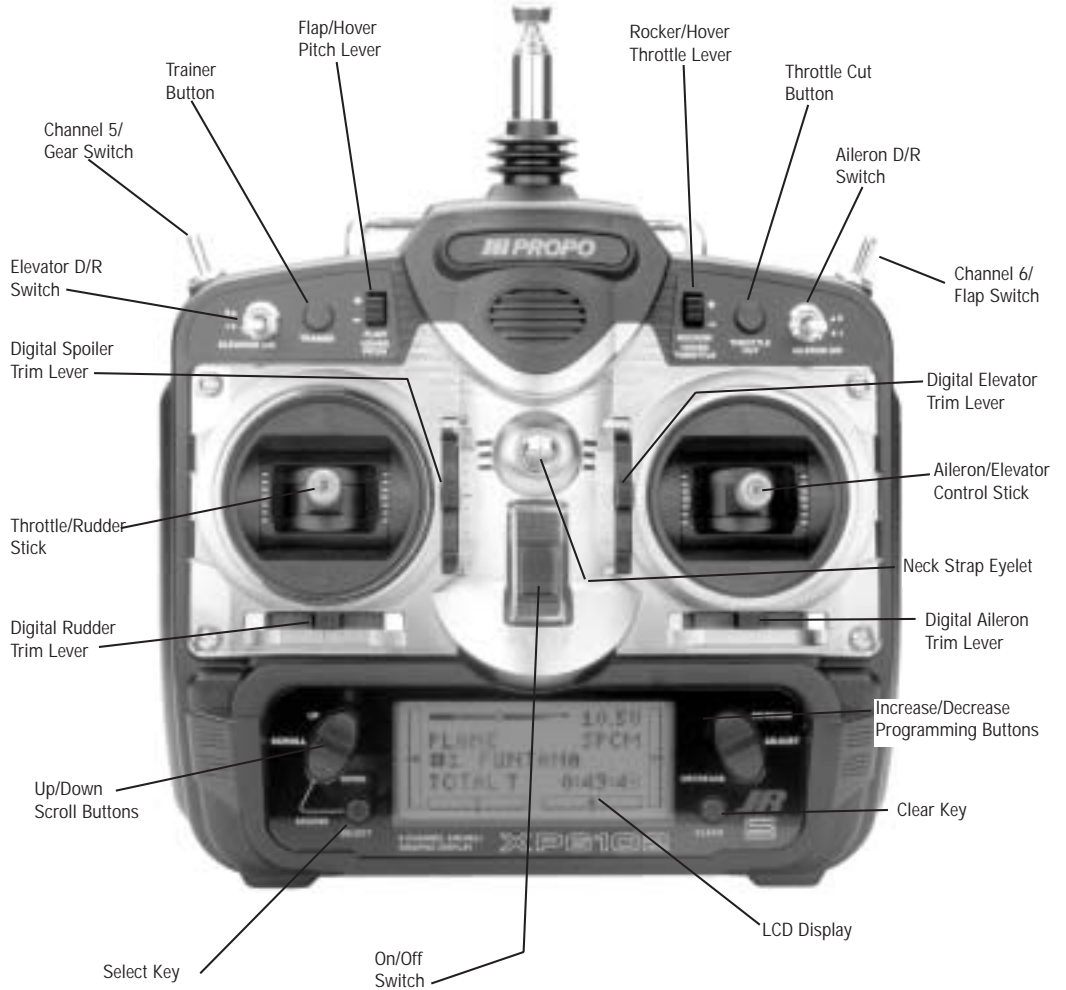

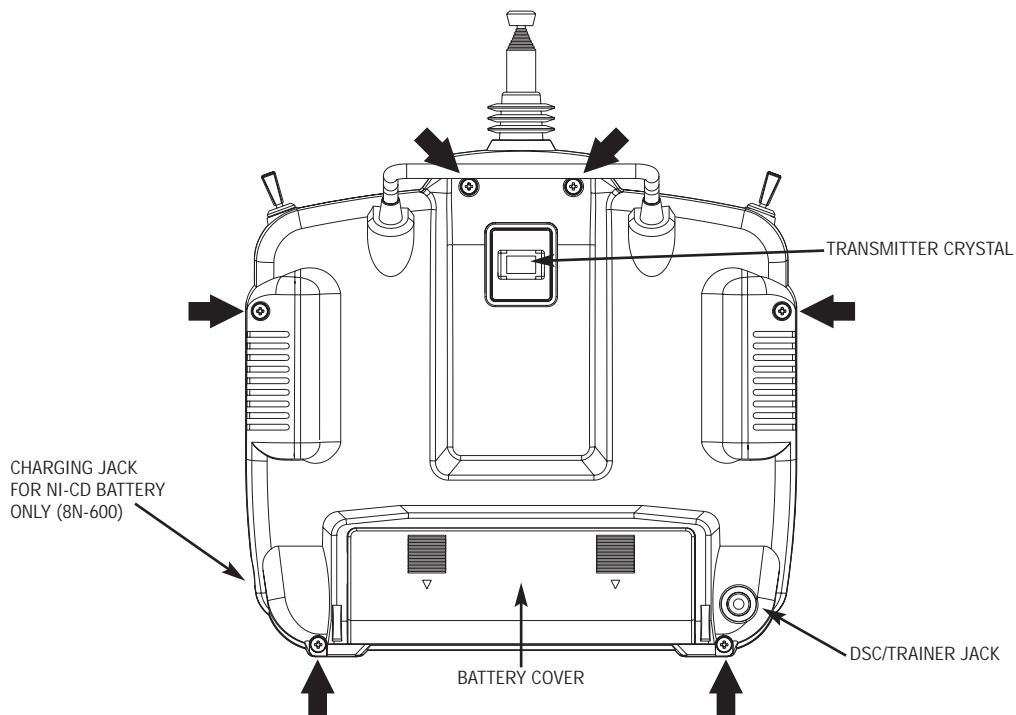

CAUTION: THE BATTERY CONNECTOR IS KEYSO THAT IT CAN ONLY BE PLUGGED IN ONE DIRECTION. DO NOT FORCE.

**Transmitter Crystal Replacement Notice**

The Federal Communications Commission (FCC) requires that changes in transmitter frequency must be performed only by an authorized service technician (Horizon Service Center). Any transmitter frequency change made a by non-certified technician may result in a violation of the FCC rules.

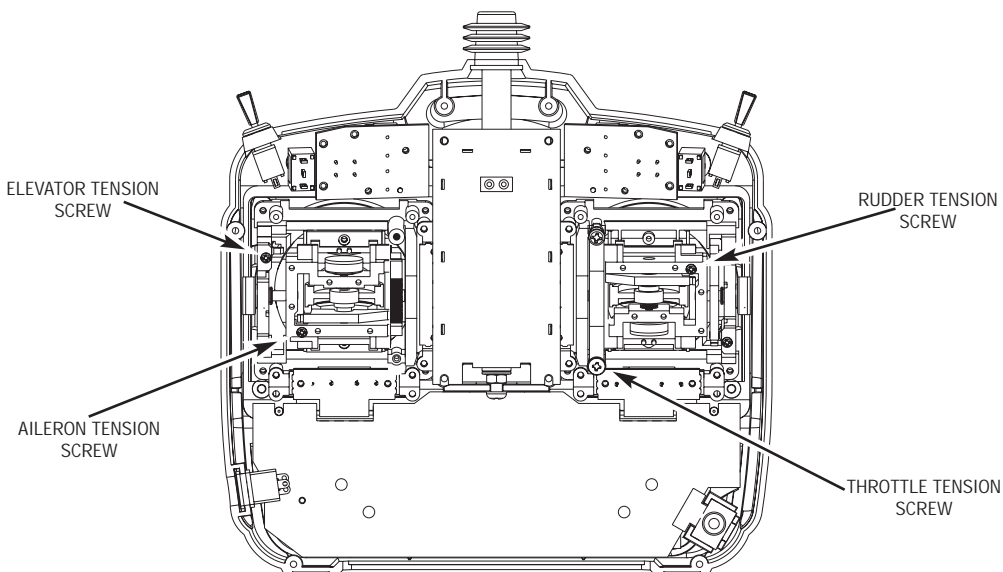

## CONTROL STICK LENGTH ADJUSTMENT

To adjust the stick length, use the 2mm Allen wrench (supplied with your XP6102 transmitter) to unlock the set screw. Turn the wrench counterclockwise to loosen the screw. Then, turn the stick clockwise to shorten or counterclockwise to lengthen. After the control stick length has been adjusted to suit your flying style, tighten the 2mm set screw. If you desire longer sticks, JR® offers a stick (JRPA047) that

is approximately one inch longer than standard. This stick, crafted from bar stock aluminum, is available at your local JR dealer.

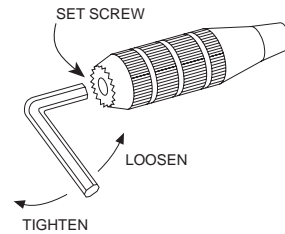

## CONTROL STICK TENSION ADJUSTMENT

Remove the Ni-Cd battery and six transmitter back screws as shown on the previous page. Remove the transmitter back, being careful not to cause damage to any components.

Adjust each screw for desired tension (counter-clockwise to loosen stick feel; clockwise to tighten stick feel). When adjusting the throttle ratchet tension, make sure that the adjusting screw does not touch the PC board after adjustment is complete.

## DIRECT SERVO CONTROL (DSC)

### For proper DSC hook-up and operation:

1. Leave the transmitter power switch in the Off position. The transmitter will not transmit any radio frequency (RF) in this position.
2. Plug the (supplied) DSC cord into the DSC port in the rear of the transmitter.
3. The encoder section of the transmitter will now be operational and the LCD display will be lit.
4. Plug the other end of the DSC Cord into the receiver charge receptacle. Turn the switch harness to the On position.

**Note:** When you install the charging jack, be sure to hook the charging jack receptacle securely into the switch harness charge cord.

### Why you should use the DSC function:

1. The DSC enables you to check the control surfaces of your aircraft without drawing the fully operational 200mAh from your transmitter battery pack. Instead, you will only draw

approximately 70mAh when using the DSC function.

2. The DSC function allows you to make final adjustments to your airplane without transmitting any radio signals. Therefore, if another pilot is flying on your frequency, you can still adjust your aircraft and not interfere with the other pilot's aircraft.

**Note:** This function is for bench-checking your airplane only.

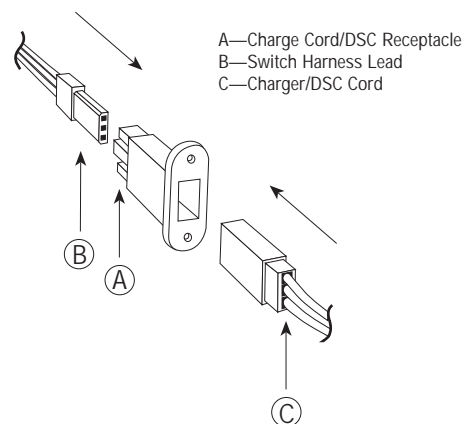

A—Charge Cord/DSC Receptacle  
B—Switch Harness Lead  
C—Charger/DSC Cord



An eyelet is provided on the face of the XP6102 transmitter that allows you to connect a Neck Strap (JRPA023). This

hook has been positioned so that your transmitter has the best possible balance when you use the neck strap.

## BASE LOADED ANTENNA

An optional base-loaded antenna is available for use with the XP6102 transmitter. It is considerably shorter than the standard antenna. However, the base loaded antenna cannot be collapsed for storage inside the transmitter. You must also use an adapter (JRPA156) to attach

the antenna to your XP6102. The Base Loaded Antenna (JRPA155) is made of a flexible coil and is covered with a soft plastic material. Your range will not be affected when using the base loaded antenna.

## FREQUENCY NOTES/AIRCRAFT ONLY FREQUENCIES

The XP6102 transmitter employs a plug-in crystal for the transmitter that is glued in place at the time of shipment. Per FCC regulation, the transmitter crystal should only be changed by a certified technician. Changing of the transmitter crystal by a non-authorized technician could result in a violation of FCC rules.

The XP6102 can transmit in either Pulse Code Modulation (PCM) or Pulse Position Modulation (PPM, commonly referred to as FM).

### **Be certain to observe the following guidelines:**

Do not operate your transmitter when another transmitter is using the same frequency, regardless of whether the second transmitter is PCM, PPM (FM) or AM. You can never operate two transmitters on the same frequency simultaneously without causing interference.

### **Aircraft-Only Frequencies**

JR® Transmitters and receivers are available in 72MHz frequencies in the United States for use with model aircraft. Employing 72MHz frequencies does not require a special operator's license from the Federal Communications Commission (FCC).

\* A chart for all available frequencies is located on page 87 of this manual.



## 2A

### INSTALLATION REQUIREMENTS

It is extremely important that your radio system be correctly installed in your model. Here are a few suggestions for installing your JR® equipment:

1. Wrap the receiver in protective foam rubber that is no less than 3/8 inch thick. Secure the foam to the receiver with #64 rubber bands. This protects the receiver in the event of a crash or a very hard landing.
2. The servos should be mounted using rubber grommets and brass eyelets to isolate them from vibration. Do not over-tighten the mounting screws; this will negate the vibration absorption effect of the rubber grommets. The following diagram will assist you in properly mounting your servo. The brass eyelets are pushed from the

bottom up in the rubber grommets. When the servo screw is tightened securely, it provides the proper security as well as the proper vibration isolation for your servo.

3. The servos must be able to move freely over their entire range of travel. Make sure that the control linkages do not bind or impede the movement of any of the servos.
4. Mount all switches away from the engine exhaust and away from any high vibration areas. Make sure the switch operates freely and is able to operate over its full travel.
5. Mount the receiver antenna firmly to the airplane to ensure that it will not become entangled in the propeller or control surfaces.

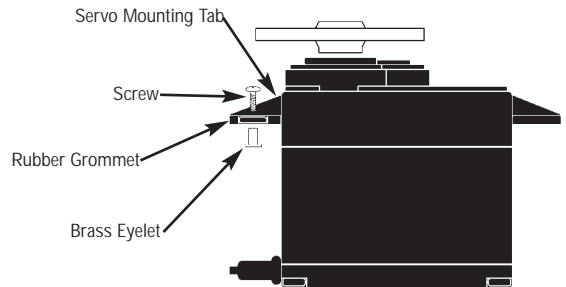

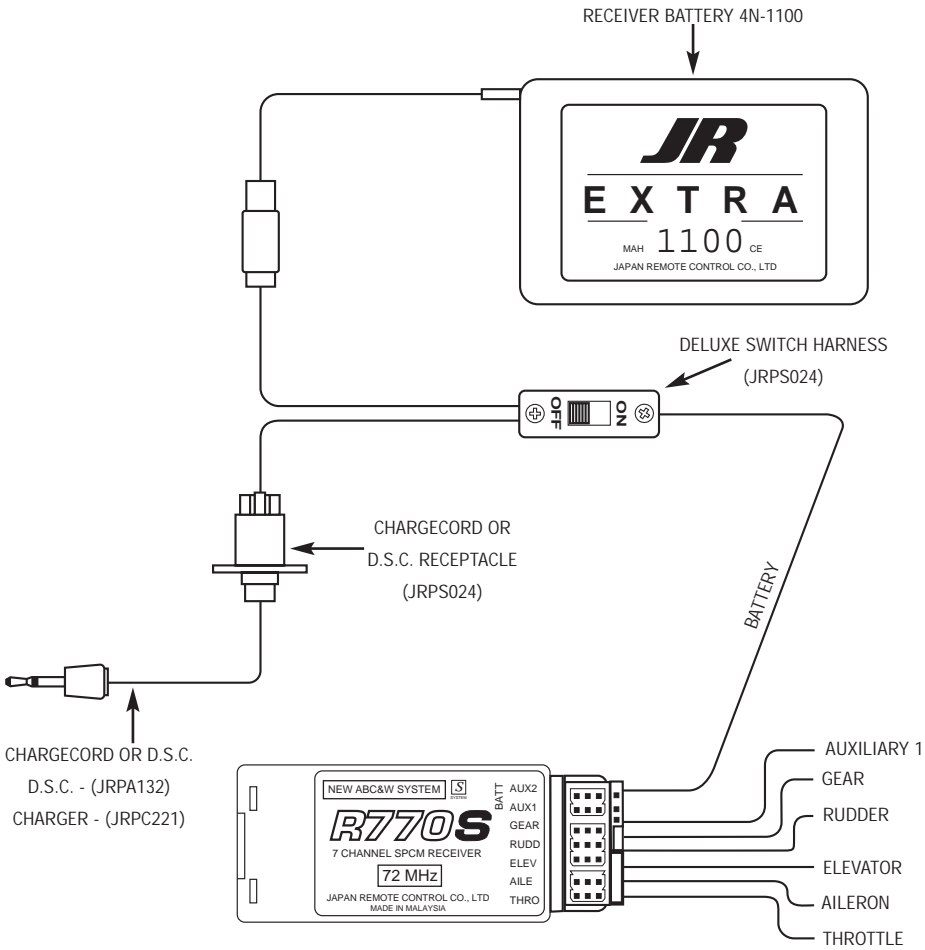

# CHAPTER 3: INPUT MODE AND FUNCTION • AIRPLANE

## 3 KEY INPUT AND DISPLAY

The **Function** keys are used to move up and down through the functions. The **Select** key is used to advance the

channel or function selected. The **Increase** and **Decrease** keys are used to make changes in the selected functions.

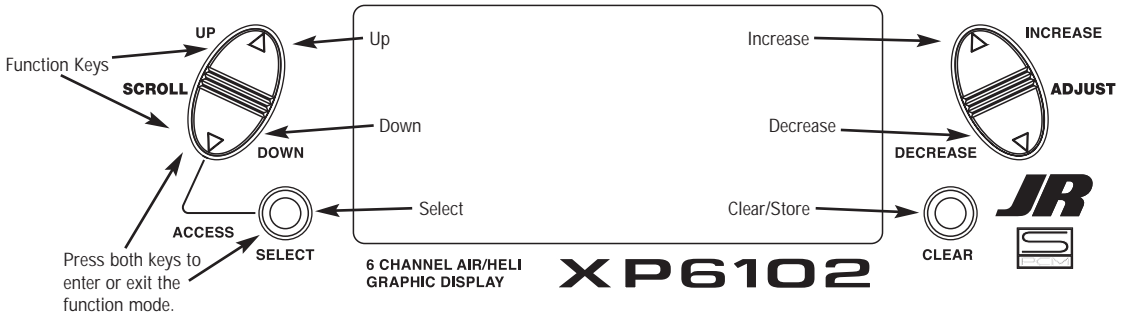

# CHAPTER 4: ALARM AND ERROR DISPLAY • AIRPLANE

## 4A BATTERY ALARM AND DISPLAY

When the transmitter voltage drops below 9.0 volts DC, the display flashes "BATT LOW" and an alarm sounds.

If you are flying when this occurs, land immediately.

## 4B BACKUP ERROR DISPLAY

All preprogrammed data is protected by a five-year lithium battery that guards against main transmitter battery failure. Should the lithium battery fail, the display will indicate BACK ERROR. If this occurs, it will be necessary to replace the lithium battery and reprogram all data. All transmitter programs will return to the

factory default settings, and the data you have input will be lost. When it becomes necessary to replace the lithium back-up battery, contact JR® Horizon Service Center. Due to the possibility of extensive damage caused by improper removal or replacement, only JR Horizon Service Center is authorized to make this change.

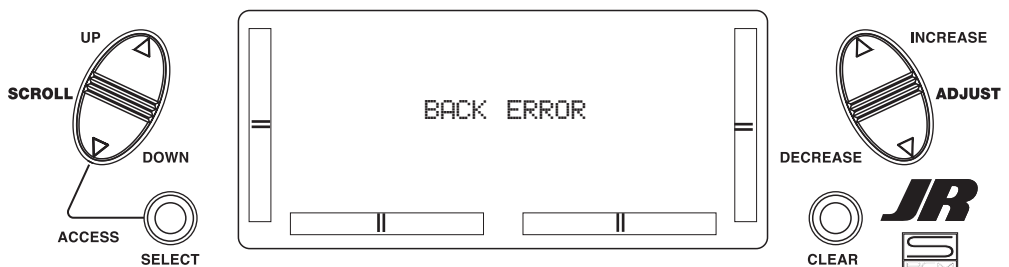

When the power switch is in the On position, the display will read as follows:

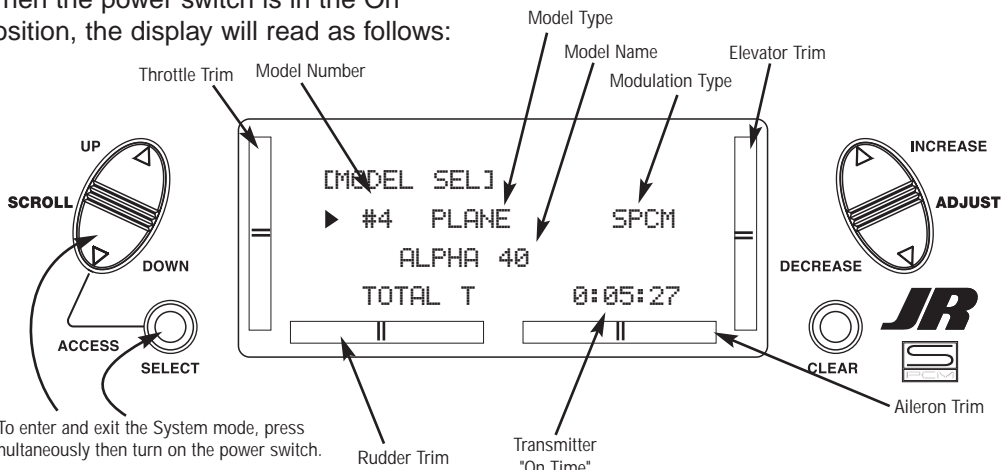

To enter and exit the System mode, press simultaneously then turn on the power switch.

To enter and exit the Function model, turn on the power switch, then press simultaneously.

To enter the System mode, press the Down and Select keys simultaneously, then turn the power switch to the on position. The display will show the last active program. Pressing either the Up or Down key then scrolls through the functions one by one, according to the system mode flowchart shown to the right. Once the appropriate function is displayed, changes can be made by pressing the (+) or (-) keys.

### System Mode Flowchart

Information pertaining to each function is explained on the page listed next to the function name. Functions will appear in the same order they are shown on this chart.

### Accessing the System Mode

1. Press the Down and Select keys simultaneously.
2. Move the power switch to the On (upper) position.
3. Use either the Up or Down key to scroll through the menu and access the applicable function.

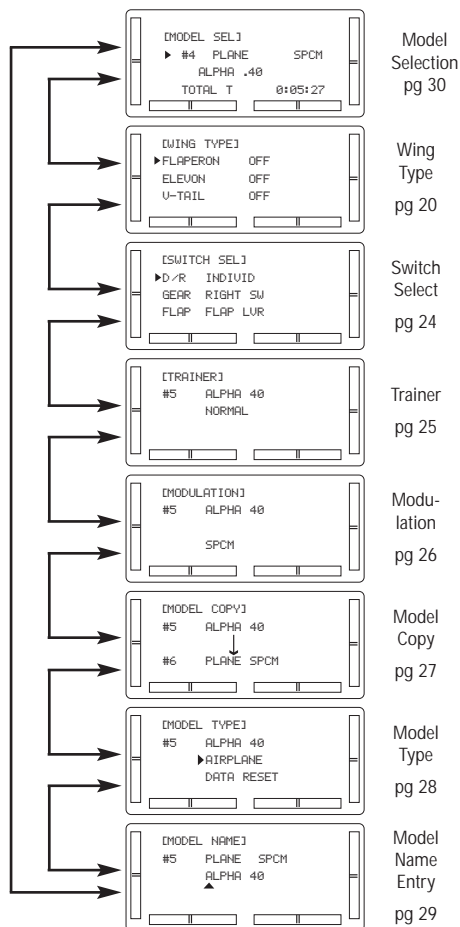
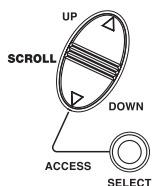

There are three different wing types to choose from; select the one that will best suit your RC aircraft. Flaperon, Elevon and V-Tail are available selections for

Wing Type and will be covered in the following pages.

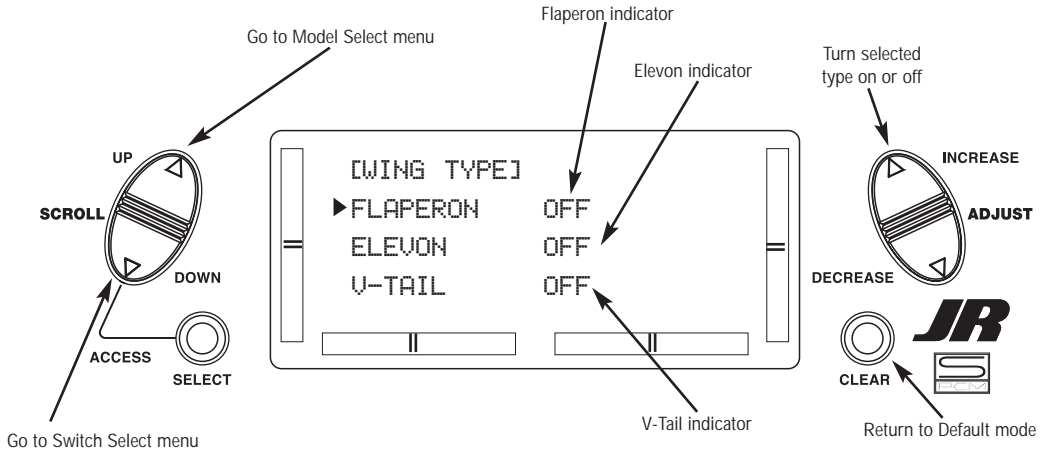

## Definition of Wing Types

**Normal-** This is used with aircraft with one servo operating both ailerons. This mode is the default setting and is active when the Flaperon, Elevon and V-Tail modes are off.

**Flaperon-** This mode is used when two servos are used to operate the ailerons. Flaperons allow each aileron to be independently adjusted. In addition, they can be programmed to move in the same direction for use as flaps or spoilers.

**Elevon-** This mode is used for some types of delta wing aircraft where the control surfaces function as both ailerons and elevators.

**V-Tail-** Used for V-tailed airplanes.

**Note:** Some functions will be unavailable when certain functions are active. With Flaperon active, Elevon will be unavailable. With Elevon active, both Flaperon and V-Tail will be unavailable. Finally, with V-Tail active, Elevon will be unavailable.



Flaperons allow you to use the existing ailerons as flaps. The ailerons can be raised or lowered in unison as flaps, yet

still remain fully operational as the ailerons of your RC airplane.

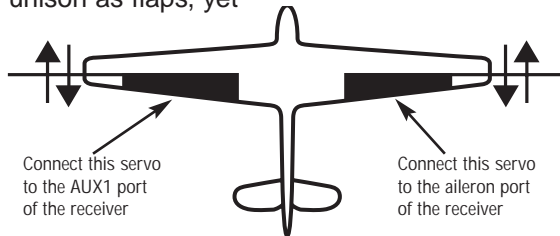

## Accessing and Utilizing the Flaperon Wing Type Selection

1. While the **Down** and **Select** buttons are pressed, move the power switch to the **On** position to access the System mode.
2. Press either the **Up** or **Down** keys until **WING TYPE** appears in the upper area of the LCD.
3. Press either the **(+)** or **(-)** key to turn on the Flaperon (FLPR) Wing Type Selection.

**Note:** For Flaperon, one servo must be used for each aileron control surface.

4. Plug the left wing aileron servo into the Auxiliary 1 (AUX 1) port of your JR receiver. Connect the right aileron servo into the aileron port (AILE) of your receiver.
5. Check to make sure that the wing servos move in the proper direction. For a right turn, the right aileron should raise while the left aileron lowers simultaneously. For a left turn, the opposite is true; the left aileron should rise while the right aileron drops. If your servos are not moving in the direction just described, use the Servo Reversing function to reverse the travel direction of the servo(s) that are moving improperly. Refer to the Servo Reversing section for information on how to reverse the travel direction.

**Note:** Each servo's travel direction is adjusted individually through the Servo Reversing function.

Once the servos achieve their proper travel direction, adjust their travel amount, dual rates, sub-trim and aileron differential.

**Note:** The applicable channel's left or right travel adjustment may be made individually by accessing the Travel Adjust function. Refer to the Travel Adjust section of this manual for more information. The fine adjustments of your aileron controls should be made in the Dual-Rate function. Refer to the Dual-Rate section for information on how to do so. You can also adjust the neutral point of your aileron servos individually through the use of the Sub-Trim function. Refer to the Sub-Trim section of this manual for more information.

6. The flap lever located on the left face of the transmitter controls the aileron movements as flaps. To turn off flaps go to the **Flap System** function on page 39 and reduce the flap value to 0%.

**Note:** Differential is offered for the Flaperon function of your XP6102. For more information, please refer to the Differential section of this manual.

8. Press the **Down** key to access the **SWITCH SEL** function.
9. Press the **Up** key to access the **MODEL SEL** function.
10. Exit the **WING TYPE** function by pressing the **Down** and **Select** keys simultaneously.



Elevon Wing Mixing is available as an option with your XP6102. This style of aircraft also employs two wing servos. However, there is not an elevator present. Instead, an elevator stick input causes the two wing servos to function in conjunction with one another to change the pitch movement of the aircraft. Also, when an aileron control is given, the two wing servos move in opposition to one another to function as ailerons.

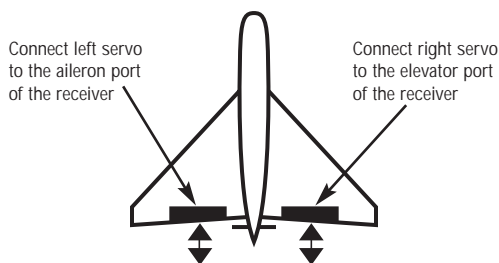

## Accessing and Utilizing the Elevon Type Selection

1. While the **Down** and **Select** keys are pressed, move the power switch to the **On** position to access the System mode.
2. Press either the **Up** or **Down** key until **WING TYPE** appears on the LCD.
3. Press the **Select** key to select the Elevon function.
4. Press either the (+) or (-) key to turn on the Elevon Wing Type function.

**Note:** The Elevon function requires one servo for each elevon, i.e. a separate servo for each wing half.

5. Plug the left elevon servo to the aileron (AILE) of your JR receiver. Connect the right elevon servo into the elevator (ELEV) port of your receiver.
6. Check to make sure the servos move in the proper direction. When an input is given from the elevator stick, they should move in unison to achieve the proper up/down elevator command. If your servos do not move as described above, use the Servo Reversing function to reverse the travel direction.

**Note:** Each servo's direction is adjusted individually through the Servo Reversing function. For more information, refer to the Servo Reversing section in this manual.

7. Once the servos direction has been set, adjust their travel direction, travel volume, dual rates, sub-trim and aileron differential.

**Note:** The applicable channel's left or right, up or down travel adjustments can be made individually. Refer to the Travel Adjust section in this manual for more information.

8. Relative to the note above, each servo's travel volume is automatically reduced to 75% of the operating range. This is to ensure that the servo does not operate beyond its capabilities. Failure to observe extreme caution when adjusting the value for the elevon servos may result in damage to the servos by over traveling.

**Note:** Fine adjustments of the elevons should be made in the Dual-Rate function. For more information, refer to the Dual-Rate section in this manual. You can also adjust the neutral point of your elevon servos individually using the Sub-Trim function as described in the Sub-Trim section of this manual. Differential is offered for the elevon function of your XP6102. For more information, refer to the Differential Aileron Mixing section of this manual.

9. Press the **Down** key to access the **SWITCH SEL** function.
10. Press the **Up** key to access the **MODEL SEL** function.
11. To exit the **WING TYPE** function, press the **Down** and **Select** keys simultaneously.



## V-Tail Type Selection

V-tail mixing is available as an option with your XP6102. V-Tail equipped aircraft require two servos.

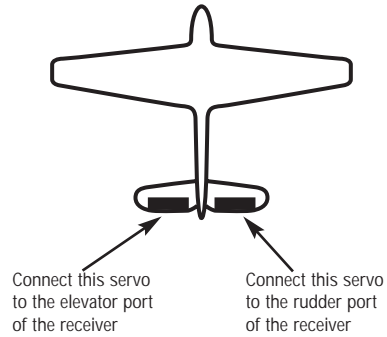

## Accessing and Utilizing the V-Tail Type Selection

1. While the **Down** and **Select** keys are pressed, move the power switch to the **On** position to access the System mode.
2. Press either the **Up** or **Down** key until **WING TYPE** appears on the LCD.
3. Press the **Select** key to select the **V-Tail** function.
4. Press either the (+) or (-) key to turn on the **V-Tail Wing Type** function.
5. Connect the servo that controls the left tail control surface to the elevator (#3) channel in the receiver and the servo that controls the right control surface to the rudder (#4) channel in the receiver.

**Note:** Individual functions like reversing, travel adjust, dual rates, sub trims etc. are available for each servo independently.

6. Check to make sure the servos move in the proper direction. When an input is given from the elevator stick, they should move in unison to achieve the proper up/down elevator command. If your servos do not move in the correct direction, use the Servo Reversing function to reverse the travel direction.

**Note:** Each servo's direction is adjusted individually through the Servo Reversing function. For more information, refer to the Servo Reversing section in this manual.

7. Once the servos direction has been set, adjust their travel direction, travel adjust, dual rates, sub-trim.

**Note:** The applicable channel's left or right, up or down travel adjustments can be made individually. Refer to the Travel Adjust section in this manual for more information.

8. Relative to the note above, each servo's travel volume is automatically reduced to 50% of the operating range. This is to ensure that the servo does not operate beyond its capabilities. Failure to observe extreme caution when adjusting the value for the elevon servos may result in damage to the servos by over traveling.

**Note:** Fine adjustments of the V-Tail should be made in the Dual-Rate function. For more information, refer to the Dual-Rate section in this manual. You can also adjust the neutral point of your V-Tail servos individually using the Sub-Trim function as described in the Sub-Trim section of this manual.

9. Press the **Down** key to access the **SWITCH SEL** function.
10. Press the **Up** key to access the **MODEL SEL** function.
11. To exit the **WING TYPE** function, press the **Down** and **Select** keys simultaneously.



The XP6102 allows the several options to be programmed for the dual rate, gear and flap switches.

Aileron and elevator dual rates can be programmed to be individually selected via its own switch (*Individ*) or the aileron, elevator and rudder functions can be combined to operate from one of four switches.

The gear channel can be programmed to operate on one of four switched or rockers or it can be inhibited, helpful for some types of mixing. Plus the flap channel can be programmed to operate from switches or levers.

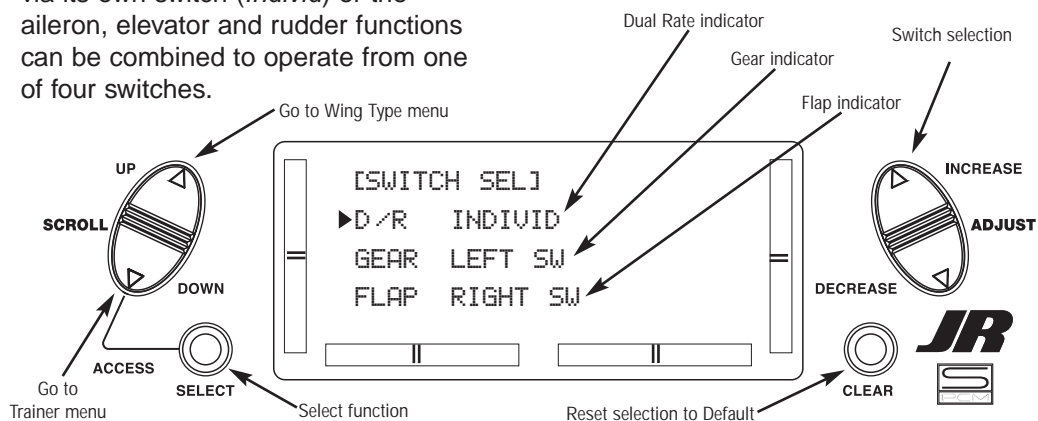

## Accessing the Modulation Function

### Dual Rates

D/R INDIVID (default) - In this mode the aileron and elevator rates are independently selected using the ELEV D/R and AILE D/R switches.

**Note:** In this mode the rudder D/R is always in the 0 position and is not selectable. This is the default setting.

COM AILE - In this mode the aileron, elevator and rudder dual rates are combined on the AILE D/R switch.

COM ELEV - In this mode the aileron, elevator and rudder dual rates are combined on the ELEV D/R switch.

COM R-SW - In this mode the aileron, elevator and rudder dual rates are combined on the upper right (flap) switch.

COM L-SW - In this mode the aileron, elevator and rudder dual rates are combined on the upper left (gear) switch.

### Gear Channel

LEFT SW (default) - The gear channel operates from the left upper (gear) switch.

AILE D/R - The gear channel operates from the aileron dual rate switch.

ROCKER - The gear channel operates from the right rocker switch and offers three positions.

INHIBIT - The gear channel is inhibited and is centered making it useful as a slave channel for mixing.

RIGHT SW - The gear channel operates from the right upper (flap) switch.

### Flap Channel

RIGHT SW (default) - The flap channel operates from the right upper (flap) switch.

LEFT SW - The flap channel operates from the left upper (gear) switch.

ELEV D/R - The flap channel operates from the elevator dual rate switch.

FLAP LVR - The flap channel operates from the left flap lever and is proportional.



The XP6102 offers a programmable trainer function with three trainer options:

**Normal Mode** - In this mode the transmitter acts as a conventional buddy-box system. The transmitter can be used as a slave or as a master: however in this mode, the reversing switches and trims must be adjusted so the slave transmitter matches the master transmitter. In normal mode, when the trainer switch is activated, the student has control of all functions and switches.

**Pilot Link** - When Pilot Link mode is used with the master transmitter, it allows the slave transmitter to be adjusted to factory defaults. The slave transmitter can simply be programmed in a model memory not being used and reset to factory defaults, thus preventing the need to synchronize the trims and reversing switches on the slave transmitter.

Also, when Pilot Link is used, the student only has control of the 4 basic channels (throttle, aileron, elevator, rudder) while the trainer (master) retains control of all other functions like gear, dual rate, programmed mixes, etc. This allows a pilot to have a test flight on a more complex airplane without having to remember complex switch positions.

**Pilot Link + Slave** - This mode is used only when the XP6102 is being used as a slave transmitter and the other Master transmitter has a Pilot Link program active. By selecting Pilot Link + Slave the transmitter is automatically in the correct programming mode to work as a slave in conjunction with another Pilot Link equipped transmitter.

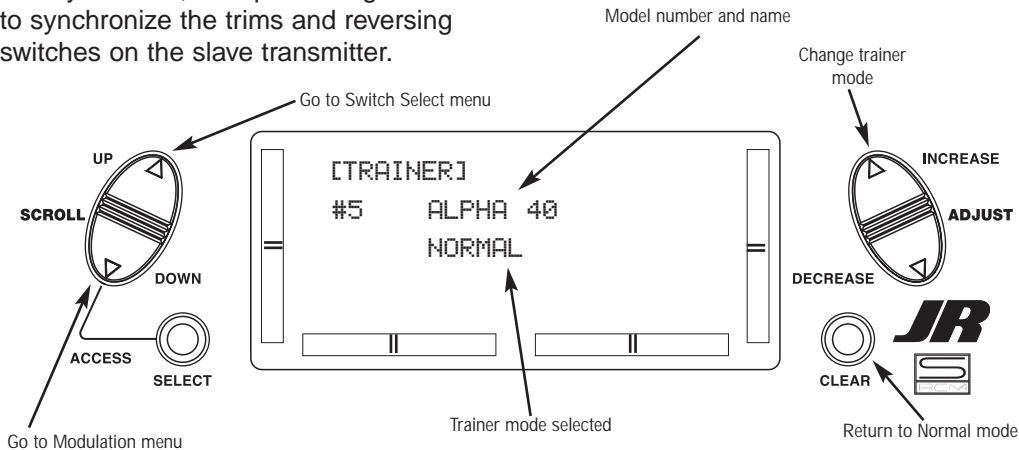

### Accessing the Trainer Function

1. Move the power switch to the *On* position while pressing the *Down* and *Select* keys to access the *System* mode.
2. Press either the *Up* or *Down* key until **TRAINER** appears at the top of the LCD.
3. Press either the (+) or (-) keys to change the Trainer Type type.
4. Pressing the *Clear* key will return the trainer function to the "normal" setting.
5. Press the *Down* key to access the **MODULATION** function.

6. Press the *Up* key to access the **SWITCH SEL** function.
7. To exit the **TRAINER** function, press the *Down* and *Select* keys simultaneously.

**Note:** The slave transmitter must always be in PPM modulation to operate.

Pilot Link + Slave automatically selects PPM modulation when activated.

When using other models of transmitters it will be necessary for the slave transmitter to be in PPM mode for the XP6102.



The Modulation Selection function enables your XP6102 to transmit to a variety of JR® receivers. You can select from either S-PCM (Pulse Code Modulation) or from PPM (Pulse Position Modulation [FM]).

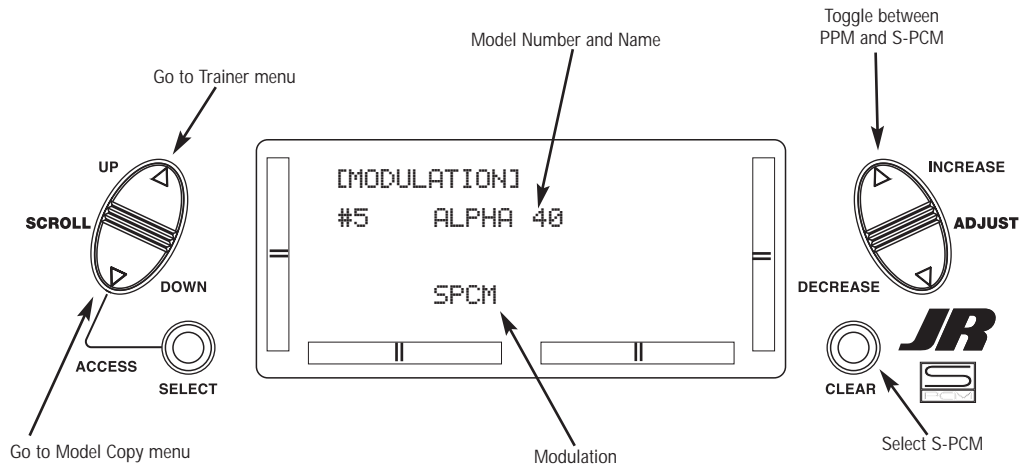

## Accessing the Modulation Function

1. Move the power switch to the *On* position while pressing the **Down** and **Select** key to access the **System mode**.
  2. Press either the **Up** or **Down** key until **MODULATION** appears at the top of the LCD.
  3. Press either the (+) or (-) keys to change the modulation type.
  4. Pressing the **Clear** key will also reset the modulation selection to the factory preset S-PCM.
  5. Press the **Down** key to access the **MODEL COPY** function.
  6. Press the **Up** key to access the **TRAINER** function.
  7. To exit the **MODULATION** function, press the **Down** and **Select** keys simultaneously.
- Note:** In the normal display, the selected modulation type will appear in the upper right of the LCD.



The Copy Selection function enables you to copy all of the settings of the current model to another model within the same transmitter. This is very useful when

setting up one aircraft several different ways or when trying an alternative setup of your current model.

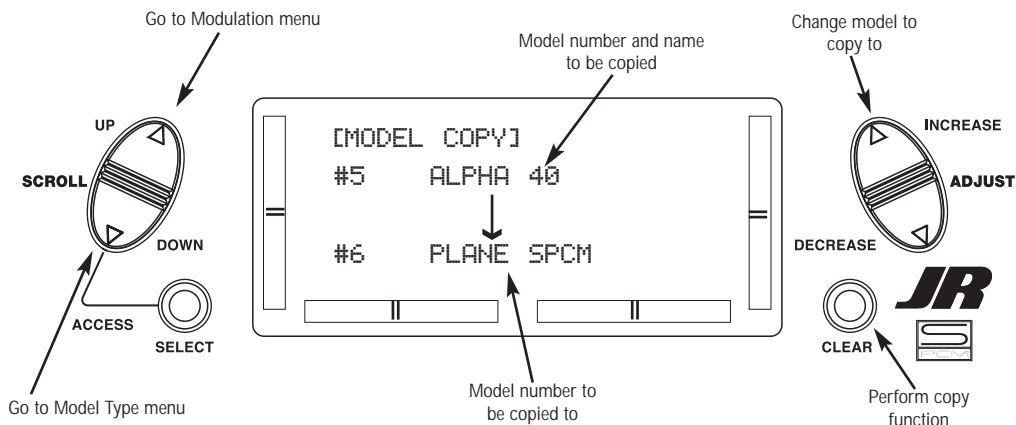

## Accessing the Model Copy Function

1. While pressing the **Down** and **Select** keys, move the transmitter's power switch to the *On* position.
2. Press either the **Up** or **Down** key until **MODEL COPY** appears on the top left of the LCD.
3. The upper number that appears is the current model. This is important to note as only the current model will be the copied. Press the (+) or (-) keys to select the desired program (lower number) to copy the current model to.
4. Next, press the **Clear** key. The current model will then be copied to the selected model.

**Note:** Always make sure that the accepting model is either free of input or one which you no longer want to retain in your transmitter's memory. Once the copying process has been completed, the information of the accepting model is lost and the current model is input as the new data.

5. Press the **Up** key to access the **MODULATION** function.
6. Press the **Down** key to access the **MODEL TYPE** function.
7. Press the **Down** and **Select** keys simultaneously to exit the **MODEL COPY** function.

The XP6102 is capable of performing as a helicopter or airplane radio with full functions for each.

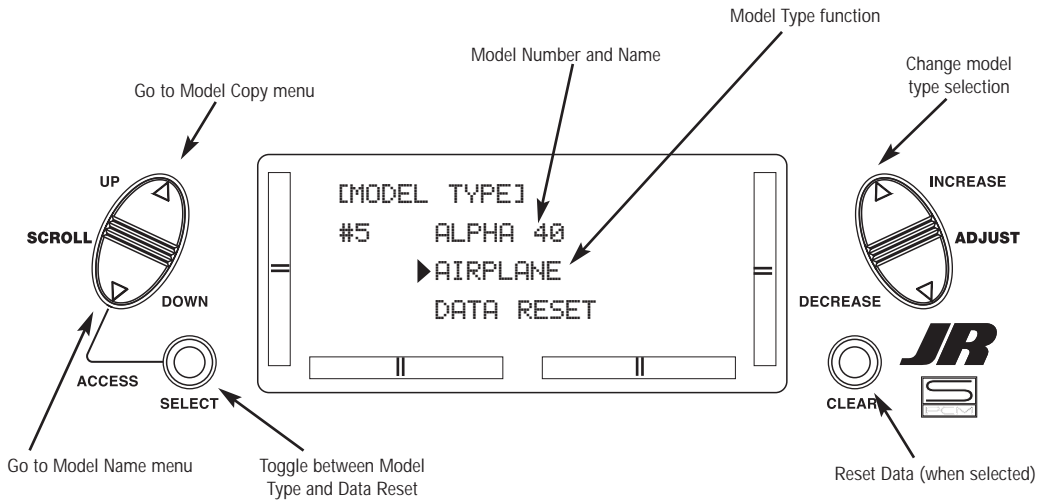

## Accessing the Type Selection Function

1. While pressing the **Down** and **Select** keys, switch the transmitter to the **On** position to enter the Model Setup mode.
2. Press either the **Up** or **Down** keys until **MODEL TYPE** is displayed in the left portion of the LCD.
3. Pressing either the (+) or (-) key will change the type of model.
4. Press the **Select** key to move the cursor to the Data Reset position.
5. Press the **Clear** key to reset the memory to the factory defaults.
6. Press the **Down** key to access the **MODEL NAME** function.
5. Press the **Up** key to access the **MODEL COPY** function.
6. Press the **Down** and **Select** keys simultaneously to exit the **MODEL TYPE** function.



The XP6102 allows an 8-digit name to be input for each of the ten models available. The current model will be displayed in the Normal display.

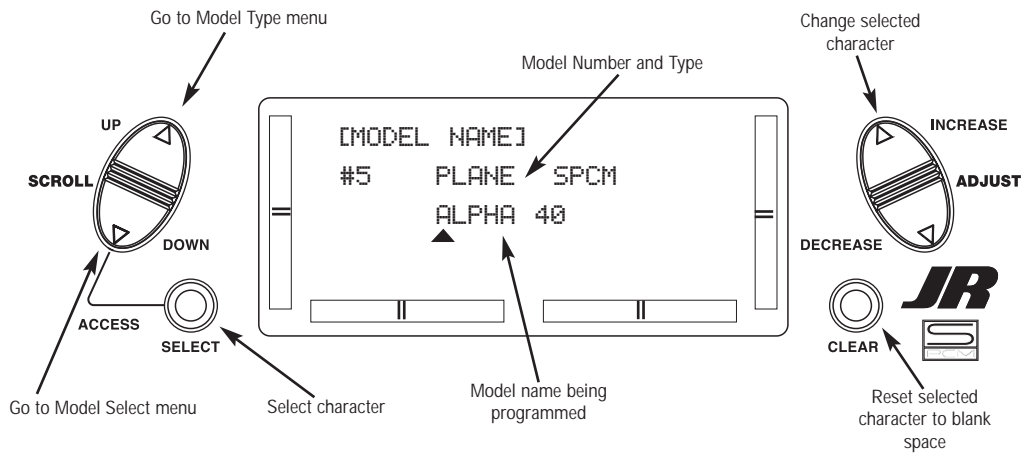

## Accessing the Model Name Entry Function

1. While pressing the **Down** and **Select** keys, switch the transmitter to the *On* position to enter the Model Setup mode.
2. Press the **Up** or **Down** key until **MODEL NAME** is displayed.
2. Press either the **Up** or **Down** key to select the first character for the model name.
4. Press the **Select** key to advance the character selection to the next character.
5. Repeat this procedure until all eight characters have been selected.
6. Press the **Down** key to access the **MODEL SEL** function.
7. Press the **Up** key to access the **MODEL TYPE** Selection function.
8. Press the **Down** and **Select** keys simultaneously to exit the **MODEL NAME** function.



The XP6102 system offers memory for ten completely separate models. Therefore, it is possible to have a mixture of helicopter and airplane setups retained in memory. It is also recommended that the Model Name

Entry function be used in conjunction with each model setup. Another very useful function of the Model Selection function is the ability to set one aircraft up several different ways. This is helpful when multi-task performance is desired.

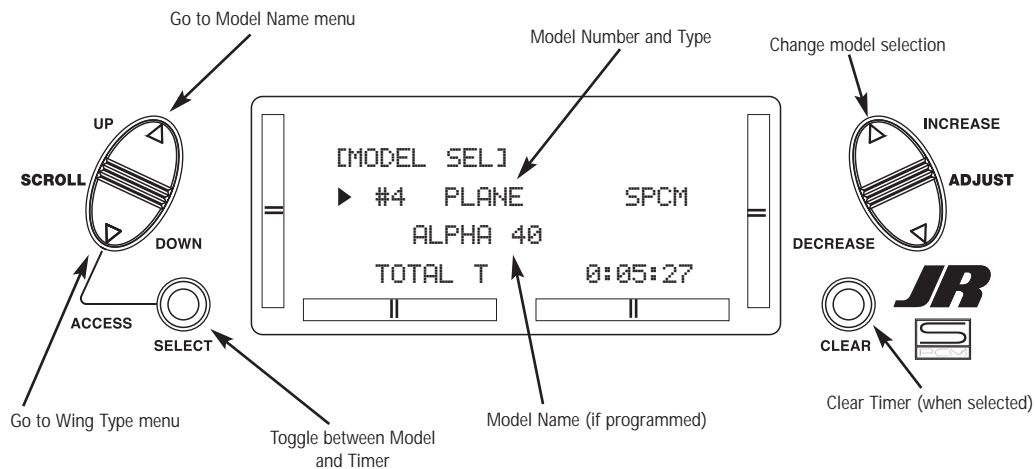

## Accessing the Model Select Function

1. While pressing the **Down** and **Select** keys, switch the transmitter to the *On* position to enter the Model Select mode.
2. Model Select will be displayed on the upper left portion of the LCD. If not, press the **Up** or **Down** key until **MODEL SEL** is displayed.
3. Pressing the (+) or (-) key will select among each of the ten models available. Notice that as each model is selected, its name appears in the LCD.
4. Once the desired model is displayed on the left, pressing the **Down** and **Channel** keys simultaneously will exit the Model Selection function and establish the model displayed as the new current model.
5. Press the **Select** key to select the timer function to clear the Total Timer. Press the **Clear** key to clear the Total timer.
6. Press the **Down** key to access the **WING TYPE** function.
7. Press the **Up** key to access the **MODEL NAME** function.
8. Press the **Down** and **Select** keys simultaneously to exit the **MODEL SEL** function.



To enter the Function mode, switch the transmitter power switch to the On position. Press the Down and Select keys simultaneously, and the display will show the last active program. Pressing either the Up or Down key then scrolls through the functions one by one, according to the Function Mode Flowchart shown below. Once the appropriate function is displayed, changes can be made by pressing the (+) or (-) keys. To select another channel of a particular function,

press the Select key. The Function mode is the most often used system to input data.

### Function Mode Flowchart

Information pertaining to each function is explained on the page listed next to the function name. Functions will appear in the same order they are shown on this chart.

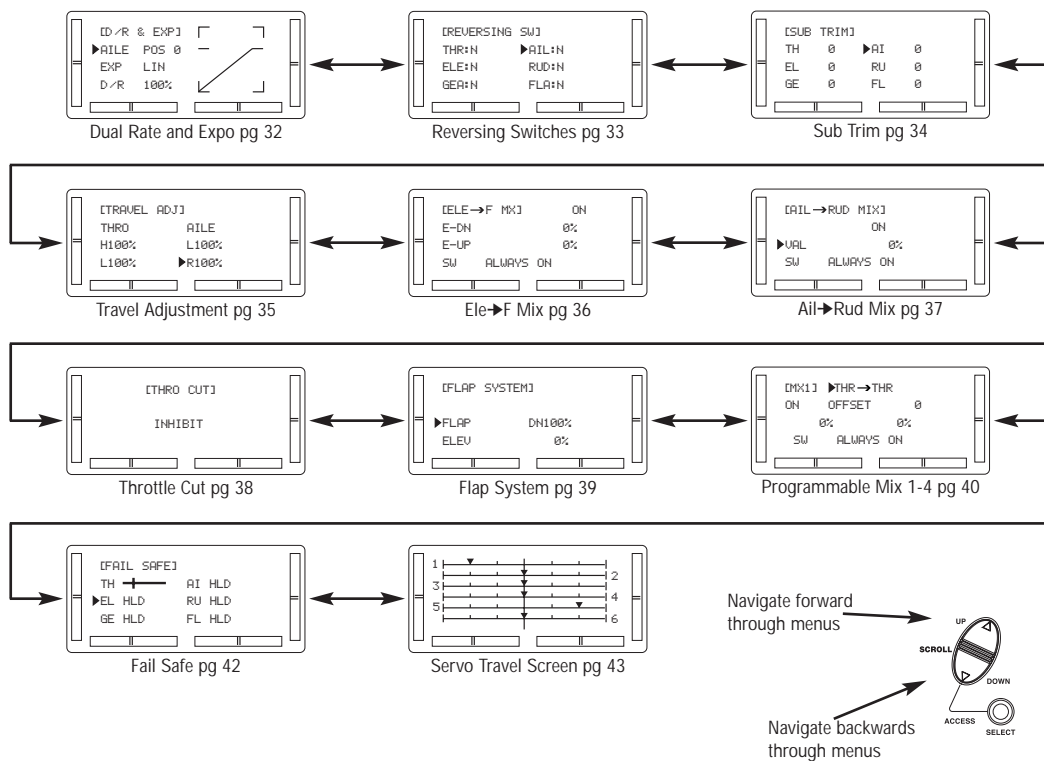

### Accessing the Mode Function

1. Move the power switch to the On position.
2. Press the Down and Select keys simultaneously.
3. Use either the Up or Down to scroll through the menu and access the applicable function.



Dual rates are available for the aileron, elevator and rudder channels of your R/C aircraft. The combined Dual Rate Function is discussed on Page 24 - Switch Select. Dual rates may be defined as the ability to vary the travel or throw rate of a servo from a switch. Due to the differing travel rates, you will find that the sensitivity of the control either increases or decreases accordingly. A higher rate, or travel, yields a higher overall sensitivity. You may find it easier to think of the Dual-Rate function as double-rates or half-rates.

Exponential reduces the sensitivity in the middle portion of stick movement, while still allowing full travel at the end of the stick movement. The end result (travel) remains the same, although exponential changes the rate at which it achieves this travel. The adjustable range is from 0–100%. Zero percent (0%) is linear stick control, meaning the response rate is equal throughout the stick control. 100% is full exponential. The larger the exponential value, the less servo action or sensitivity you will notice around the neutral setting.

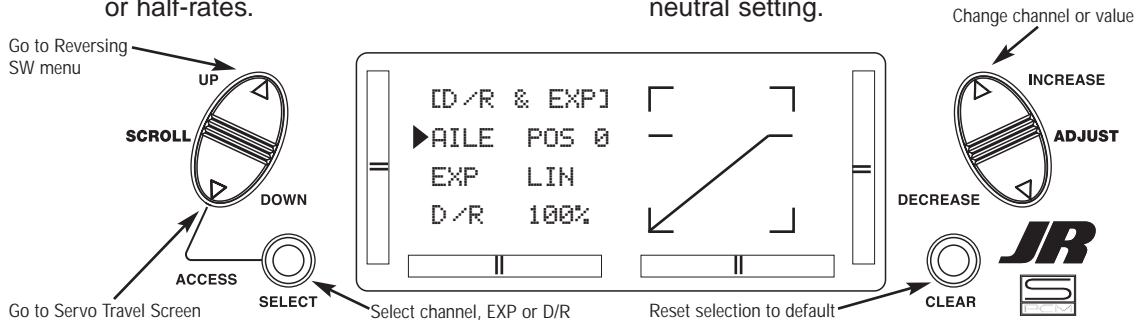

The amount of travel is adjustable from 0–125% in 1% increments. The factory setting, or default value, for both the 0 and 1 switch positions is 100%.

Either switch position may be selected as the low or high rate by placing the switch in the desired position and adjusting the value accordingly.

## Accessing the Dual-Rate and Exponential Function

1. Place the transmitter power switch in the *On* position.
2. Access the Function mode by pressing the *Down* and *Select* keys simultaneously.
3. Press either the *Up* or *Down* key until **D/R & EXP** appears in the upper left corner of the LCD.
4. Press the (+) or (-) key until the desired channel (aileron, elevator or rudder) appears.
5. Select the switch position for which you want to adjust the rate. The number to the upper right of the current rate value on the display indicates the current position of the Dual-Rate switch for the channel that you have selected. Either a 0 or a 1 will be shown, corresponding to the position of the switch. To select the opposite switch position, move the appropriate Dual
6. Rate switch to the opposite position. The number that appears above the current rate value reflects the change.
7. Adjust the rate for the channel and the switch position just selected. To decrease the throw rate, move the cursor to the D/R position using the *Select* key, then press the (-) key. To increase the throw rate, press the (+) key. As stated previously, the adjustable rate is from 0–125% for each switch position and channel.
8. Press the *Up* arrow key to access the **REVERSING SW** menu.
9. Press the *Down* arrow key to access the **SERVO TRAVEL SCREEN**.
10. Press the *Down* arrow and *Select* keys simultaneously to exit the **DUAL RATE AND EXPONENTIAL** mode.



The Reverse Switch function is an electronic means of reversing the throw of a given channel (servo). All six

channels of the XP6102 offer reversible servo direction. This will ease setup during the servo installation into your aircraft.

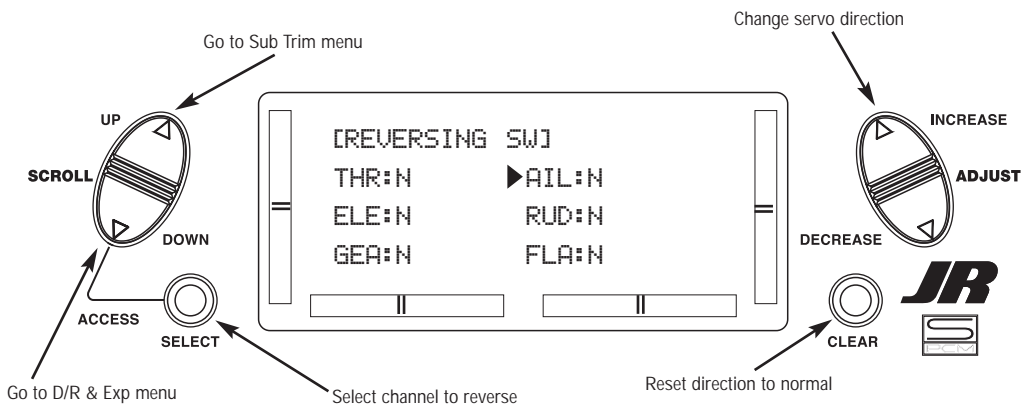

## Accessing the Servo Reversing Function

1. Place the transmitter switch in the *On* position.
2. Access the Function mode by pressing the *Down* and *Select* keys simultaneously.
3. Press either the *Up* or *Down* key until the **REVERSING SW** appears in the upper portion of the LCD.
4. Using your transmitter's control sticks, switches and potentiometers, move the control surfaces of your aircraft. Note the travel direction of each of the corresponding control surfaces.
5. After you have determined which channel(s) need to have the throw directions reversed, use the *Select* key to call up the appropriate channel.
6. Press either the (+) or (-) keys to change the travel direction of the servo. Pressing the *Clear* key returns the travel direction to Normal.
7. You can observe the change in the travel direction by moving the appropriate control at this time.
8. Access the **D/R & EXP** function by pressing the *Down* key.
9. Access the **SUB TRIM** function by pressing the *Up* key.
10. Exit the **SERVO REVERSING** function by pressing the *Down* and *Select* keys simultaneously.



The Sub Trim Adjustment function allows you to electronically fine-tune the centering of your servos. Individually adjustable for all six channels with a range of  $\pm 125\%$  ( $\pm 30$  degrees servo travel).

The sub trim function provides precise servo arm neutral positioning if rotating the servo arm will not allow the desired servo arm position.

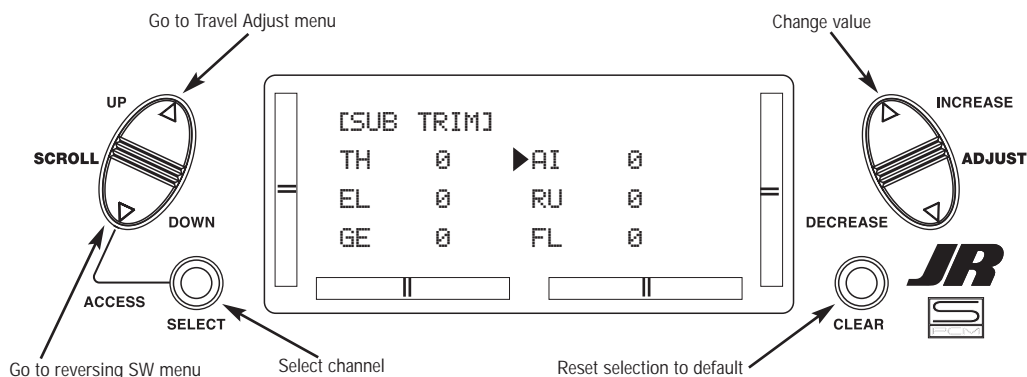

## Accessing the Sub Trim Function

1. Place the transmitter power switch in the *On* position.
2. To Access the Function mode, press the **Down** and **Select** keys simultaneously.
3. Press either the **Up** or **Down** key until **SUB TRIM** appears in the upper middle portion of the LCD.
4. Press the **Select** key until the desired channel appears.
5. Press the (+) or (-) key to establish the desired amount and direction of Sub Trim.

**Caution:** Do not use excessive Sub Trim adjustments since it is possible to overrun your servo's maximum Sub Trim. Remember that it is a trim convenience function. It is not intended to take the place of the proper mechanical trim adjustments that are necessary on any RC model.

6. Access the **REVERSING SW** function by pressing the **Down** key.
7. Access the **TRAVEL ADJ** function by pressing the **Up** key.
8. Exit the **SUB TRIM** function by pressing the **Down** and **Select** keys simultaneously.



The purpose of Travel Adjust is to offer you precise servo control deflection in either direction of servo operation. The XP6102 offers travel adjust for all six channels. The Travel Adjust range is from

0–150% (0 degrees to 60 degrees) from neutral, or center, and it can be adjusted for each direction individually. The factory default (Data Reset) value is 100% for each direction of servo travel.

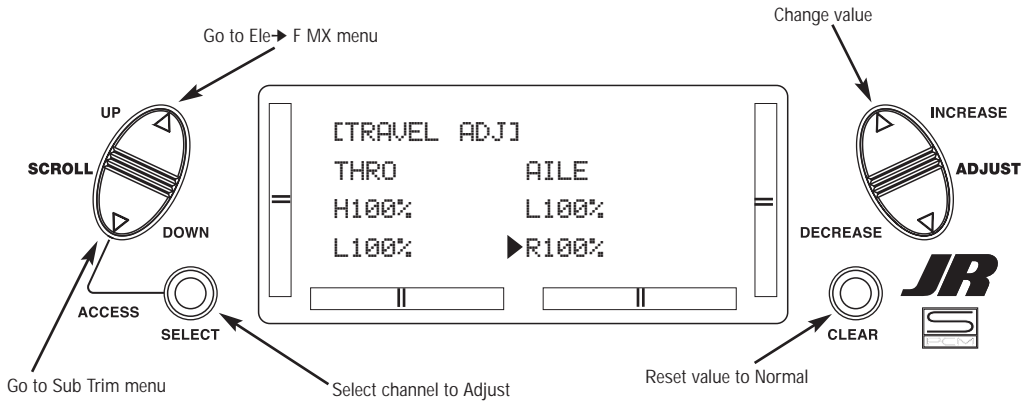

## Accessing the Travel Adjust Function

1. Place the transmitter power switch in the *On* position.
2. Access the Function mode by pressing the *Down* and *Select* keys simultaneously.
3. Press either the *Up* or *Down* key until **TRAVEL ADJ** appears in the upper portion of the LCD.
4. Press the *Select* key until the desired channel is highlighted.
5. Move the appropriate control stick (lever, switch, etc) to the right or left of center to the direction of travel you want to adjust. An arrow to the left of the travel adjust value will reflect the current position to be adjusted.
6. After the control stick or switch is placed in the direction of travel to be adjusted, press the (+) or (-) key until the proper amount of servo travel is shown on the LCD. Press the (+) key to increase the amount of servo travel. Press the (-) key to decrease the amount of servo travel.
7. Follow the same procedure for the remaining channels.
8. Access the **SUB TRIM** function by pressing the *Down* key.
9. Access the **ELE → F MX** function by pressing the *Up* key.
10. Exit the **TRAVEL ADJ** function by pressing the *Down* and *Select* keys simultaneously.



When this system is active and a value of flaps is input, the flaps will be deflected each time the elevator stick is

used. The actual flap movement is adjustable for both up and down elevator. A switch can be assigned to turn the elevator to flap mixing on or off.

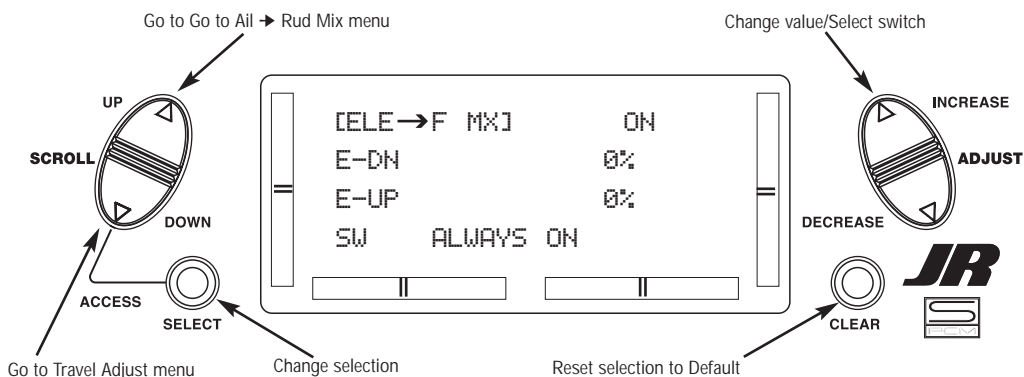

## Accessing the Elevator to Flap Function

1. Place the transmitter power switch in the *On* position.
  2. Access the Function mode. To do so, press the **Down** and **Select** keys simultaneously.
- Press either the **Up** or **Down** key until **ELE -> F MX** appears in the upper portion of your LCD.
3. Move the elevator stick in the direction you want to mix with flaps.

**Note:** The position indicator will reflect this change by highlighting the up or down arrow.

5. Press the (+) or (-) key to increase or decrease the amount of flaps to be mixed. If you want to reverse the flap travel, press the **Clear** key, bringing the mixing value to the factory default (0%), and increase the value using the opposite key (+) or (-) from the key originally selected.

6. Once you have adjusted the first mixing position (up or down), place the elevator stick in the opposite direction and follow Step 5 above to adjust the second elevator mixing value.
7. Access the switch position by pressing the **Select** key. Use the (+) or (-) keys to select from the one of six switches, or from always on.
8. Access the **TRAVEL ADJ** function by pressing the **Down** key.
9. Access the **AIL -> RUD MIX** Mixing function by pressing the **Up** key.
10. Exit the **ELE -> F MX** function by pressing the **Down** and **Channel** keys simultaneously.



This form of mixing is designed so that when input to the aileron stick is given, the rudder servo will also move, eliminating the need to coordinate these controls manually.

When adjusting, if an opposite mixing direction of the rudder servo is required, simply press the (+) or (-) keys to change

the mixing value from a (+) to (-). This will reverse the mixing direction of the rudder from its original direction. The switch used to activate this mix can also be selected as explained below. The factory default is a value of 0%.

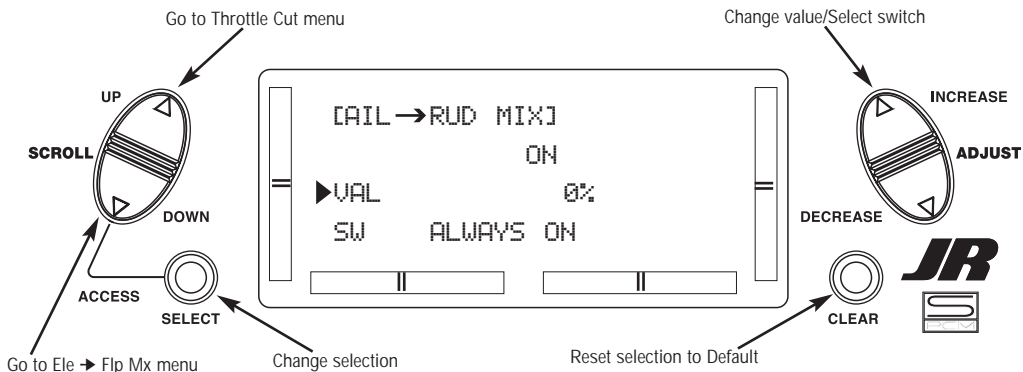

## Accessing the Aileron to Rudder Mixing Function

1. Place the transmitter power switch in the *On* position.
2. Access the Function mode. To do so, press the *Down* and *Select* keys simultaneously. Press either the *Up* or *Down* key until **AIL → RUD MIX** appears in the center portion of your LCD.
3. Press the (+) or (-) key to increase or decrease the amount of rudder to be mixed with aileron. If you want to reverse the Rudder Mix direction, press the *Clear* key, bringing the mixing value to the factory default (0%), and increase the value using the opposite key (+) or (-) from the key originally selected.
4. Press the *Select* key to access the switch assignment function.
5. Press the (+) or (-) key to select the desired switch/function to activate the Aileron-to-Rudder Mixing function.
6. Access the **ELE → FLP MX** mixing function by pressing the *Down* key.
7. Access the **THRO CUT** function by pressing the *Up* key.
8. Exit the **AIL → RUD MIX** function by pressing the *Down* and *Select* keys simultaneously.



This function assigns the Throttle Cut switch to the push button located on upper right front of the transmitter. The Throttle Cut function is designed to return the throttle trim to the lowest

position instantly and keep this position while the button is pressed. This feature is used to “cut” or stop the engine without changing the position of digital throttle trim.

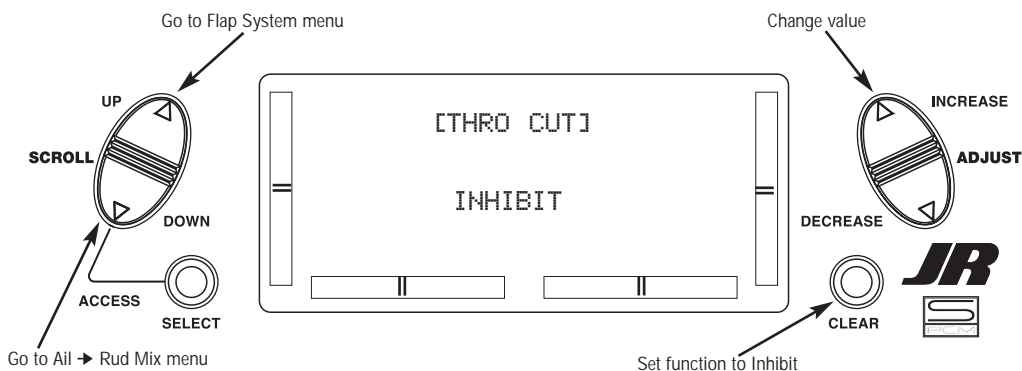

## Accessing the Throttle Cut Function

1. Place the transmitter power switch in the *On* position.
2. Access the Function mode. To do so, press the *Down* and *Select* keys simultaneously. Press either the *Up* or *Down* key until **THRO CUT** appears in the upper portion of the LCD screen.
3. Use the (+) and (-) keys to change the value of the Throttle cut function.
4. Access the **FLAP SYSTEM** mixing function by pressing the *Down* key.
5. Access the **AIL → RUD MIX** function by pressing the *Up* key.
6. Exit the **THRO CUT** function by pressing the *Down* and *Select* keys simultaneously.

**Note:** Pressing the Clear key will Inhibit the Throttle Cut, turning it off until it has been reactivated.



The Flap System function provides elevator compensation to counteract any pitch tendencies when flaps are deployed.

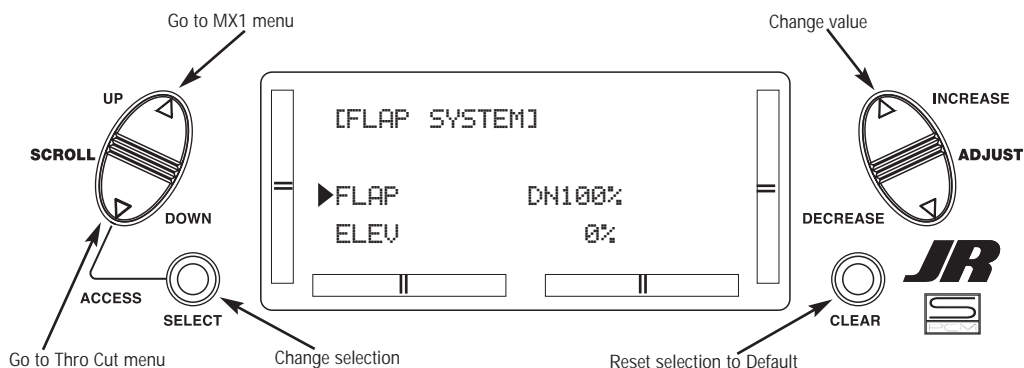

### Accessing the Flap System Function

1. Place the transmitter switch in the *On* position.
2. Press the *Down* and *Select* keys simultaneously to enter the Function mode.
3. Press either the *Up* or *Down* key until **FLAP SYSTEM** appears in the top of the LCD.
5. Press the *Select* key to select the desired channels to be adjusted.
6. Use the (+) or (-) keys to set the desired landing mode surface positions.
4. Access the **THRO CUT** mixing function by pressing the *Down* key.
5. Access the **MIX 1** function by pressing the *Up* key.
6. Exit the **FLAP SYSTEM** function by pressing the *Down* and *Select* keys simultaneously.



The XP6102 offers four programmable mixes to be used for any number of different purposes. This function allows mixing any one channel to any other channel. This mix can remain on at all times or be switched on and off in flight using a number of different switches.

Mix numbers 1-3 are of the standard variety, in that the digital trim for the master channel only affect the master channel, and not the slave channel. Mix number 4 is of the "Trim Include" variety. This mix is used any time the mix requires the slave channels trim position to be varied when the master channels digital trim position is varied. An example for this type of mix would be when dual elevator or dual aileron servos are used and connected to two separate channels of the system, rather than using a single channel with a Y-harness.

Each channel of this radio is identified by an abbreviated name. The chart below indicates the channel and its corresponding abbreviation. The channel name appearing first is known as the "master channel" or the channel to which you want to mix. The second number is known as the "slave channel" or the channel that is being mixed into the master channel. For example, AIL → RUD would indicate aileron-to-rudder mixing. Each time the aileron stick is moved, the aileron will deflect, and the rudder will automatically move in the direction and to the value input.

Mixing is proportional, so small inputs of the master channel will produce small outputs of the slave channel. Each programmable mix has a mixing "offset." The purpose of the mixing offset is to re-define the neutral position of the slave channel.

THR: Throttle  
 AIL: Aileron  
 ELE: Elevator  
 RUD: Rudder  
 GEA: Gear  
 FLA: Flap

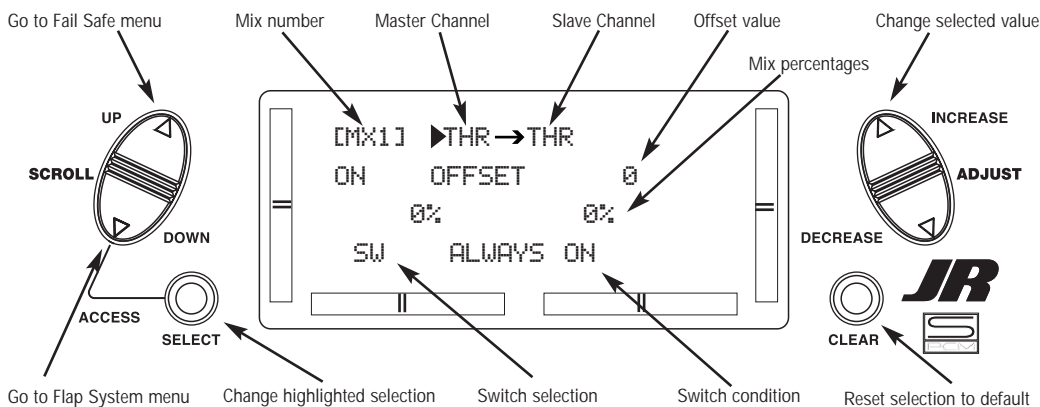

1. Place the transmitter switch in the *On* position.
2. Press the *Down* and *Select* keys simultaneously to enter the Function mode.
3. Press either the *Up* or *Down* key until **MIX 1** appears in the LCD.

## Selecting the Master and Slave Mixing Channels

4. Press the (+) or (-) keys to select the master channel.
5. Press the *Select* key to move the cursor to the slave channel position.
6. Press the (+) or (-) keys to select the slave channel.
7. Press the *Select* key once. The display will continue to show the current mixing channels at the top of the LCD, but now an arrow will indicate the current stick position (master) to be adjusted.

## Setting the Mixing Values

8. While holding the master stick in the direction you want to mix, press the (+) or (-) keys to increase or decrease the mixing value for the slave channel. The value in the LCD will change to display the current mix value selected. Next, hold the master stick to the other side to adjust the mix for the other direction.

## Setting the Mixing Switch Activation

9. Press the *Select* key until the SW is highlighted. The LCD with "ALWAYS ON" indicates the current switch that this mix is currently selected to always be active (ON).

## Mixing Operation and Switches

Each mixing program can be turned on and off by a lever or switch. The levers and switches that can be selected for program mixing are tabulated at the right with their abbreviations appearing on the display and their corresponding positions.

The mix switch options are:

ALWAYS ON  
 RIGHT FWD  
 RIGHT REA  
 LEFT FWD  
 LEFT REA  
 AILE D/R  
 ELEV D/R

## Setting the Mixing Channel Offset

1. Press the *Select* key until offset is highlighted. The display will show the current mixing channels at the top of the LCD, with the word "OFFSET" in the center of the LCD. The value to the right is the mixing Offset neutral point, currently 0.
2. A new value for the offset can be selected using the (+) or (-) keys. This is the new neutral point for the slave channel (Point that the mix is activated). Press the *Clear* key to reset the value back to 0.
3. Press the *Down* and *Select* keys simultaneously to exit the Programmable Mix function.

With a little practice, programmable mixing will become easier to understand. Mixing is only limited by your imagination.



The Fail Safe/Hold function is available only when you use the XP6102 transmitter in PCM modulations. This function is designed to help minimize damage to your aircraft during a loss of signal to the receiver. The servos either assume the fail-safe presets or hold their last good signal position.

As noted earlier, if you are in the PPM modulation, the Fail-Safe/Hold function is not applicable. Therefore, the Fail-Safe/Hold function will not appear on your LCD screen menu while in the PPM mode. Refer to the Modulation Selection section for more information pertaining to the broadcast signal of your XP6102 transmitter.

**Note:** The throttle fail safe position is defaulted to the idle position for added safety.

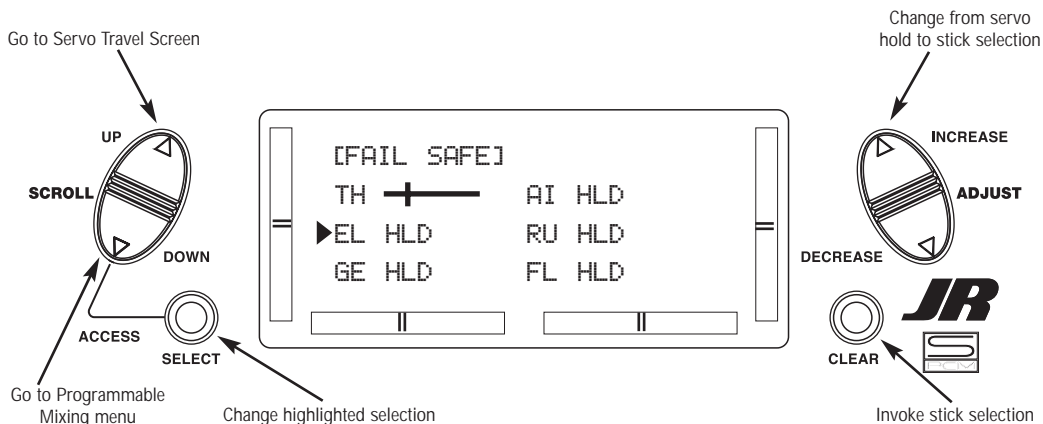

## Accessing the Fail Safe Function

1. Place the transmitter power switch in the *On* position.
2. Access the Function mode. To do so, press the *Down* and *Select* keys simultaneously. Press either the *Up* or *Down* key until **FAIL SAFE** appears in the upper portion of the LCD screen.
3. Use the *Select* key to highlight the servo function to set.
4. Use the (+) or (-) keys to toggle between servo hold or setting the servo position.
5. When using the servo setting position, move the corresponding control stick to the position where you want the servo if the radio enters into the fail safe mode. Press the *Clear* key to have the transmitter memorize all stick position.
6. Repeat steps 4 and 5 until all six controls have been set.
7. Access the **SERVO TRAVEL** screen by pressing the *Up* key.
8. Access the **MIXING FUNCTIONS** function by pressing the *Up* key.
9. Exit the **FAIL SAFE** function by pressing the *Down* and *Select* keys simultaneously.



The Servo Travel Screen is used to verify the stick movements of the transmitter.

It can also be used to verify the mixing functions have been performed correctly without the need to turn on the aircraft.

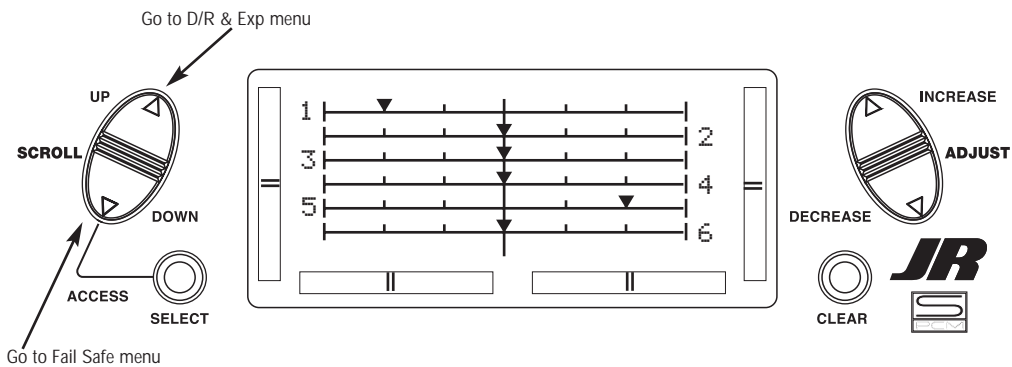

## Accessing the Servo Travel Screen

1. Place the transmitter power switch in the *On* position.
2. Access the Function mode. To do so, press the *Down* and *Select* keys simultaneously. Press either the *Up* or *Down* key until the **SERVO TRAVEL** screen appears.
3. Move the sticks. The the indicators correspond to the following:
 

Indicator 1:	Throttle
Indicator 2:	Aileron
Indicator 3:	Elevator
Indicator 4:	Rudder
Indicator 5:	Gear
Indicator 6:	Flap
4. Access the **D/R & EXP** screen by pressing the *Up* key.
5. Access the **FAIL SAFE** function by pressing the *Up* key.
6. Exit the **SERVO TRAVEL** screen function by pressing the *Down* and *Select* keys simultaneously.



# XP6102 DATA SHEET – ACRO

MODEL NAME \_\_\_\_\_

MODEL NUMBER \_\_\_\_\_

REVERSE SW	THRO NORM • REV	AILE NORM • REV	ELEV NORM • REV	RUDD NORM • REV	GEAR NORM • REV	FLAP NORM • REV
SUB TRIM						
TRAVEL ADJUST	H      %	L      %	U      %	L      %	+      %	U      %
	L      %	R      %	D      %	R      %	-      %	D      %
FAIL SAFE (PCM)						

DUAL RATE • EXPO	0		AILE	ELEV	RUDD
		D/R	%	%	%
	EXP	%	%	%	
	1	D/R	%	%	%
EXP		%	%	%	

ELEV – FLAP MIX	UP	%
	DOWN	%

AILE – RUDD MIX	RATE	%
	SW	

PROGRAM MIX		CHANNEL	SW	+POS	-POS	OFFSET
	MIX 1	–		%	%	
	MIX 2	–		%	%	
	MIX 3	–		%	%	
	MIX 4	–		%	%	

WING TYPE	FLAPERON	
	ELEVON	
	V-TAIL	

THROTTLE CUT	
--------------	--

MODULATION	PPM • SPCM
------------	------------

FLAP SYSTEM	ELEV	%
	FLAP	

SWITCH SELECT	D/R	
	GEAR	
	FLAP	

NOTES:



Feel free to make photocopies of the data sheet for use with all your models.



## CHANNEL ASSIGNMENT/THROTTLE ALT

### Channel TX Function Airplane Function

1	THRO	Throttle Channel
2	AILE	Aileron Channel
3	ELEV	Elevator Channel
4	RUDD	Rudder Channel
5	GEAR	Gyro Channel
6	AUX 1	Auxiliary 1 Channel (Pitch)

### Throttle ALT

The Throttle ALT function makes the throttle stick trim active only when the throttle stick is at less than half throttle. This gives easy, accurate idle adjustments without affecting the high throttle position.



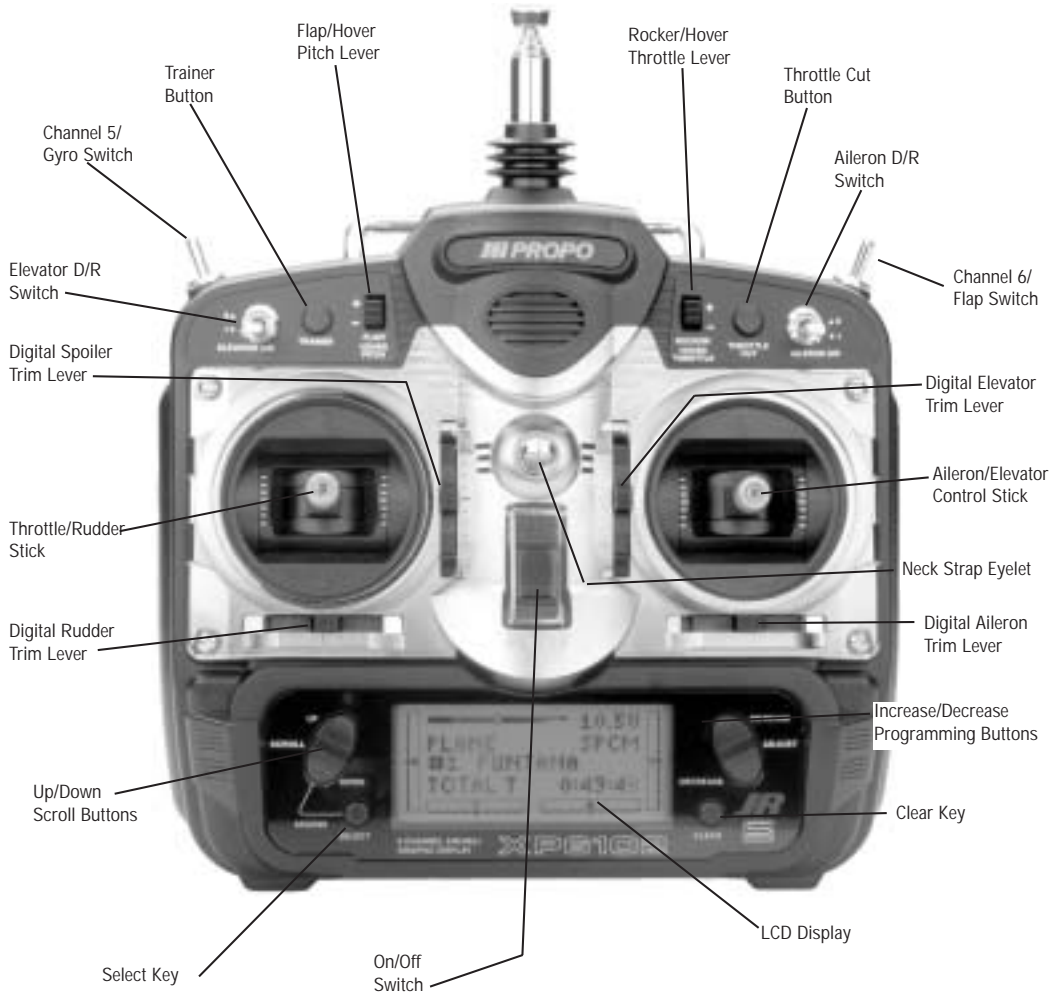

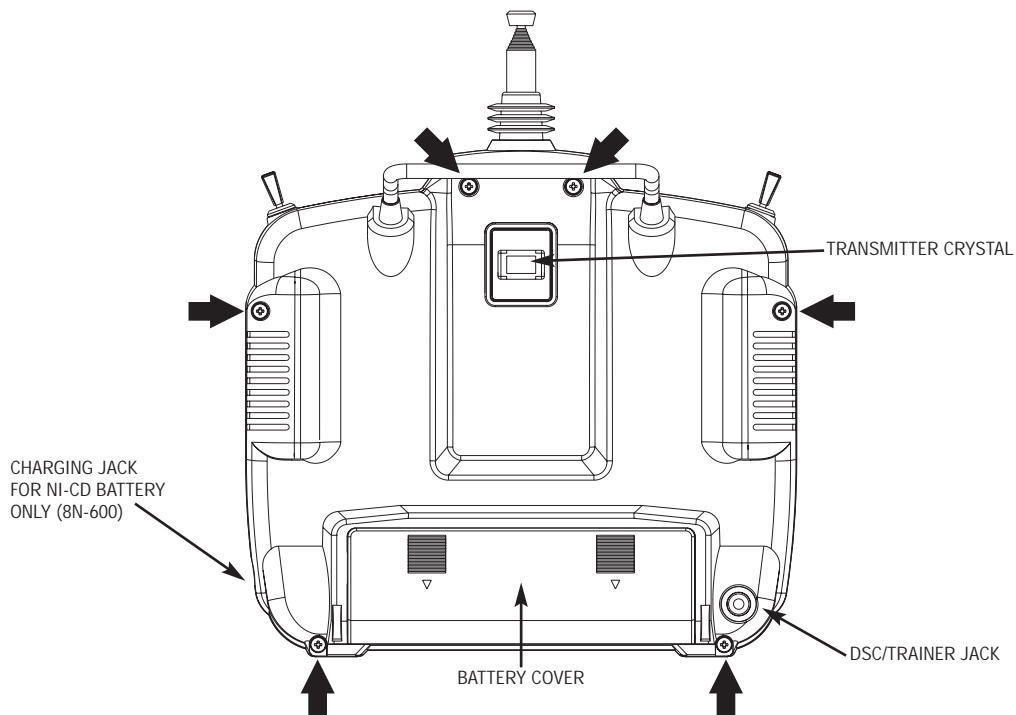

CAUTION: THE BATTERY CONNECTOR IS KEYSO THAT IT CAN ONLY BE PLUGGED IN ONE DIRECTION. DO NOT FORCE.

**Transmitter Crystal Replacement Notice**

The Federal Communications Commission (FCC) requires that changes in transmitter frequency must be performed only by an authorized service technician (Horizon Service Center). Any transmitter frequency change made by a non-certified technician may result in a violation of the FCC rules.

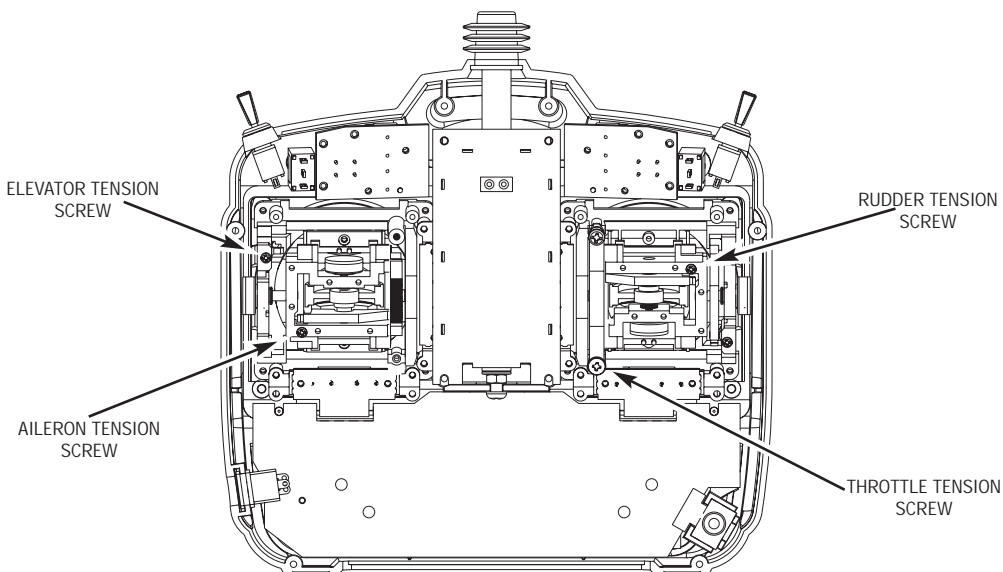

## CONTROL STICK LENGTH ADJUSTMENT

To adjust the stick length, use the 2mm Allen wrench (supplied with your XP6102 transmitter) to unlock the set screw. Turn the wrench counterclockwise to loosen the screw. Then, turn the stick clockwise to shorten or counterclockwise to lengthen. After the control stick length has been adjusted to suit your flying style, tighten the 2mm set screw. If you desire longer sticks, JR® offers a stick (JRPA047) that

is approximately one inch longer than standard. This stick, crafted from bar stock aluminum, is available at your local JR dealer.

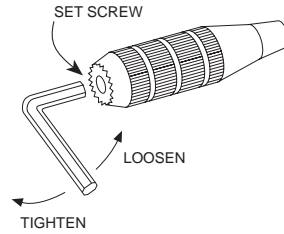

## CONTROL STICK TENSION ADJUSTMENT

Remove the Ni-Cd battery and six transmitter back screws as shown on the previous page. Remove the transmitter back, being careful not to cause damage to any components.

Adjust each screw for desired tension (counter-clockwise to loosen stick feel; clockwise to tighten stick feel). When adjusting the throttle ratchet tension, make sure that the adjusting screw does not touch the PC board after adjustment is complete.

## DIRECT SERVO CONTROL (DSC)

### For proper DSC hook-up and operation:

1. Leave the transmitter power switch in the Off position. The transmitter will not transmit any radio frequency (RF) in this position.
2. Plug the (supplied) DSC cord into the DSC port in the rear of the transmitter.
3. The encoder section of the transmitter will now be operational and the LCD display will be lit.
4. Plug the other end of the DSC Cord into the receiver charge receptacle. Turn the switch harness to the On position.

**Note:** When you install the charging jack, be sure to hook the charging jack receptacle securely into the switch harness charge cord.

### Why you should use the DSC function:

1. The DSC enables you to check the control surfaces of your aircraft without drawing the fully operational 200mAh from your transmitter battery pack. Instead, you will only draw

approximately 70mAh when using the DSC function.

2. The DSC function allows you to make final adjustments to your airplane without transmitting any radio signals. Therefore, if another pilot is flying on your frequency, you can still adjust your aircraft and not interfere with the other pilot's aircraft.

**Note:** This function is for bench-checking your helicopter only.

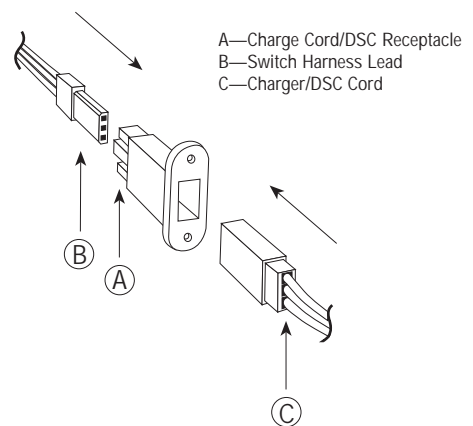

An eyelet is provided on the face of the XP6102 transmitter that allows you to connect a Neck Strap (JRPA023). This

hook has been positioned so that your transmitter has the best possible balance when you use the neck strap.

## BASE LOADED ANTENNA

7I

An optional base-loaded antenna is available for use with the XP6102 transmitter. It is considerably shorter than the standard antenna. However, the base loaded antenna cannot be collapsed for storage in side of the transmitter. You must also use an adapter (JRPA156) to

attach the antenna to your XP6102. The Base Loaded Antenna (JRPA155) is made of a flexible coil and is covered with a soft plastic material. Your range will not be affected when using the base-loaded antenna.

## FREQUENCY NOTES/AIRCRAFT ONLY FREQUENCIES

7J

The XP6102 transmitter employs a plug-in crystal for the transmitter that is glued in place at the time of shipment. Per FCC regulation, the transmitter crystal should only be changed by a certified technician. Changing of the transmitter crystal by a non-authorized technician could result in a violation of FCC rules.

The XP6102 can transmit in either Pulse Code Modulation (PCM) or Pulse Position Modulation (PPM, commonly referred to as FM).

### **Be certain to observe the following guidelines:**

Do not operate your transmitter when another transmitter is using the same frequency, regardless of whether the second transmitter is PCM, PPM (FM) or AM. You can never operate two transmitters on the same frequency simultaneously without causing interference.

### **Aircraft-Only Frequencies**

JR® Transmitters and receivers are available in 72MHz frequencies in the United States for use with model aircraft. Employing 72MHz frequencies does not require a special operator's license from the Federal Communications Commission (FCC).

\* A chart for all available frequencies is located on page 87 of this manual.



## 8A

### INSTALLATION REQUIREMENTS

It is extremely important that your radio system be correctly installed in your model. Here are a few suggestions installing your JR® equipment:

1. Wrap the receiver in protective foam rubber that is no less than 3/8 inch thick. Secure the foam to the receiver with #64 rubber bands. This protects the receiver in the event of a crash or a very hard landing.
2. The servos should be mounted using rubber grommets and brass eyelets to isolate them from vibration. Do not over-tighten the mounting screws; this will negate the vibration absorption effect of the rubber grommets. The following diagram will assist you in properly mounting your servo.
3. The servos must be able to move freely over their entire range of travel. Make sure that the control linkages do not bind or impede the movement of any of the servos.
4. Mount all switches away from the engine exhaust and away from any high vibration areas. Make sure the switch operates freely and is able to operate over its full travel.
5. Mount the receiver antenna firmly to the airplane to ensure that it will not become entangled in the propeller or control surfaces.

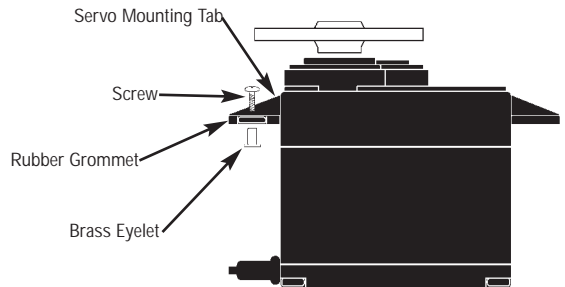

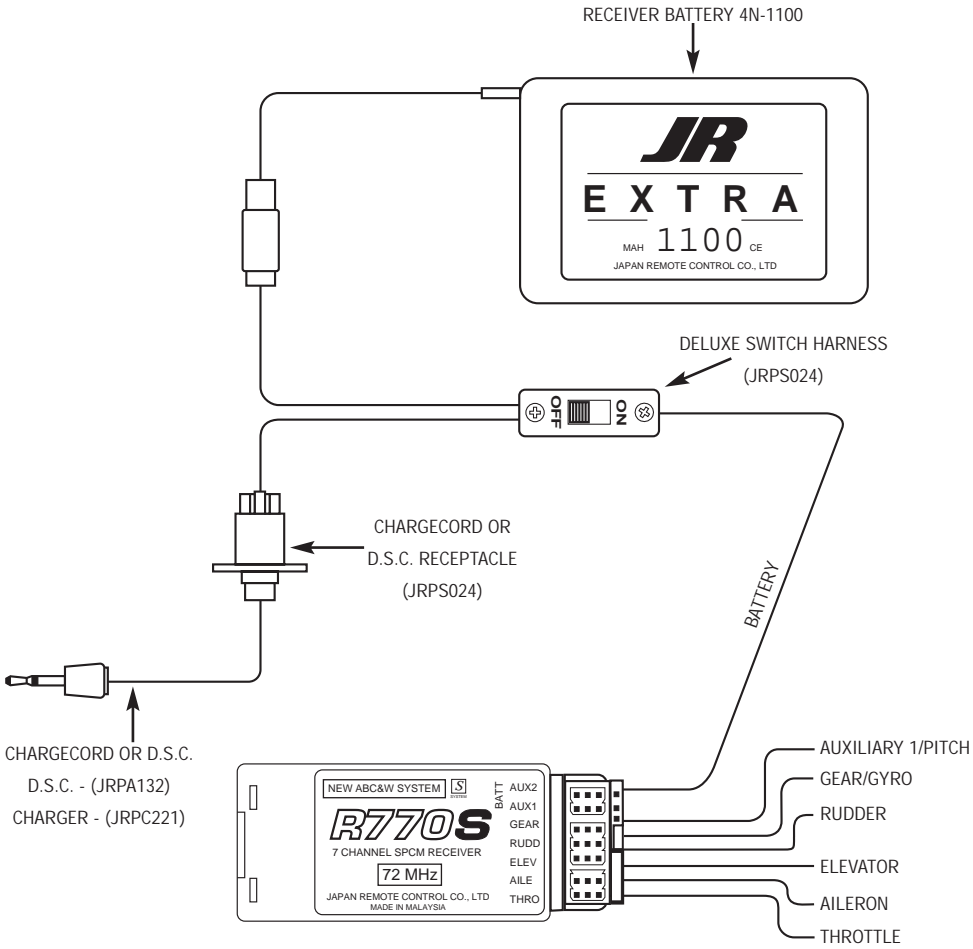

# CHAPTER 9: INPUT MODE AND FUNCTION • HELICOPTER

## 9 KEY INPUT AND DISPLAY

The **Function** keys are used to move up and down through the functions. The **Select** key is used to advance the

channel or function selected. The **Increase** and **Decrease** keys are used to make changes in the selected functions.

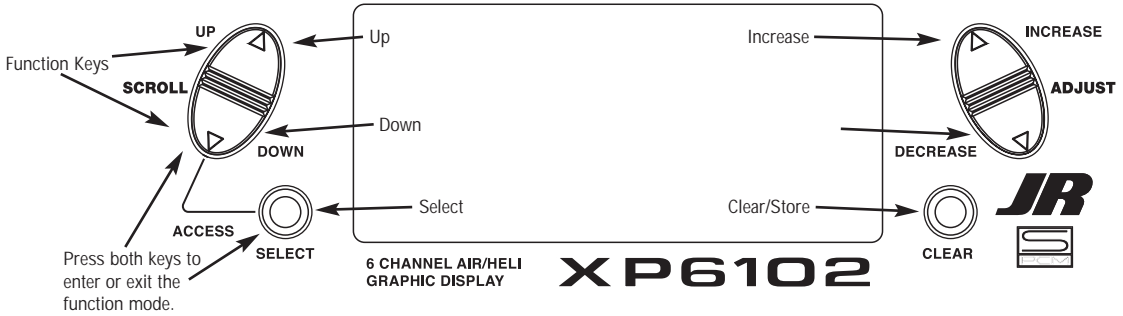

# CHAPTER 10: ALARM AND ERROR DISPLAY • HELICOPTER

## 10.A BATTERY ALARM AND DISPLAY

When the transmitter voltage drops below 9.0 volts DC, the display flashes "BATT LOW" and an alarm sounds.

If you are flying when this occurs, land immediately.

## 10.B BACKUP ERROR DISPLAY

All preprogrammed data is protected by a five-year lithium battery that guards against main transmitter battery failure. Should the lithium battery fail, the display will indicate BACK ERROR. If this occurs, it will be necessary to replace the lithium battery and reprogram all data. All transmitter programs will return to the factory default settings, and the data you

have input will be lost. When it becomes necessary to replace the lithium back-up battery, contact JR Horizon Service Center. Due to the possibility of extensive damage caused by improper removal or replacement, only JR® Horizon Service Center is authorized to make this change.

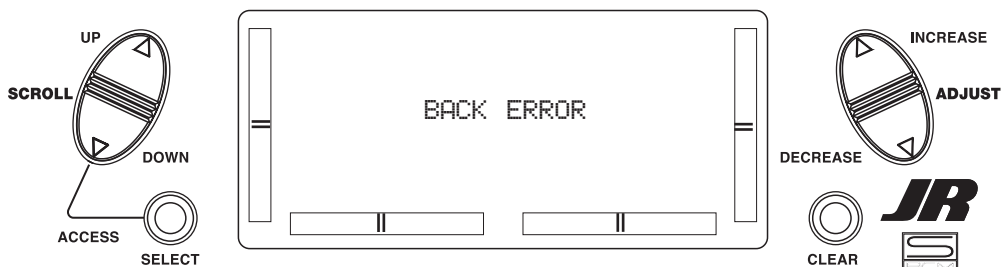

When the power switch is in the On position, the display will read as follows:

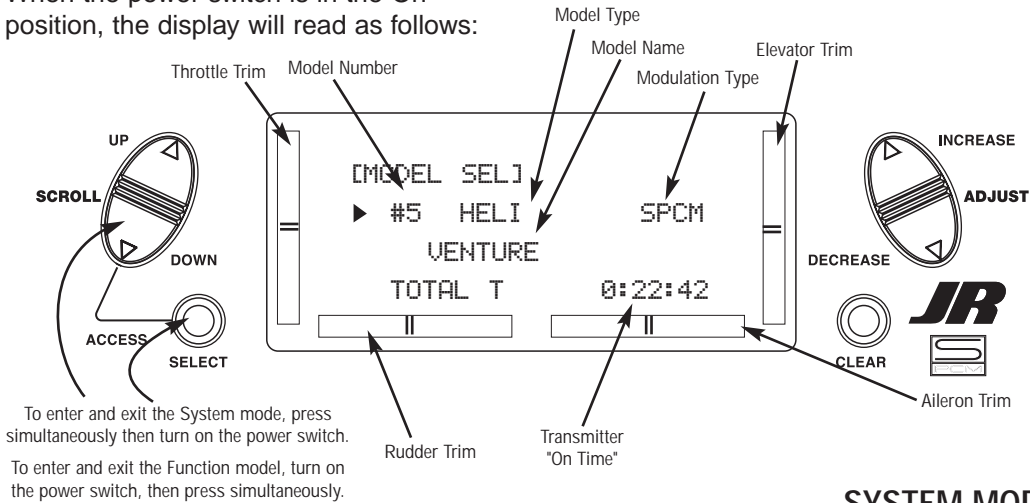

To enter the System mode, press the Down and Channel keys simultaneously, then turn the power switch to the on position. The display will show the last active program. Pressing either the Up or Down key then scrolls through the functions one by one, according to the system mode flowchart shown to the right. Once the appropriate function is displayed, changes can be made by pressing the (+) or (-) keys.

### System Mode Flowchart

Information pertaining to each function is explained on the page listed next to the function name. Functions will appear in the same order they are shown on this chart.

### Accessing the System Mode

1. Press the Down and Channel keys simultaneously.
2. Move the power switch to the On (upper) position.
3. Use either the Up or Down key to scroll through the menu and access the applicable function.

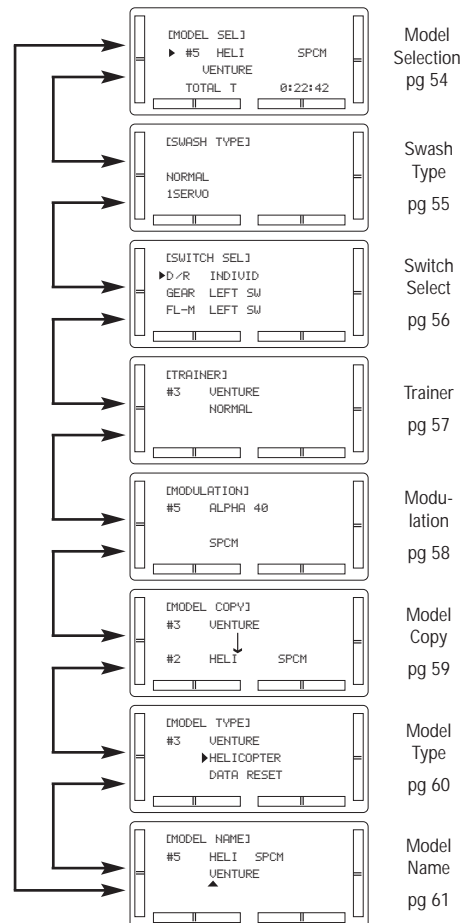

The XP6102 system offers memory for ten completely separate models. Therefore, it is possible to have a mixture of helicopter and airplane setups retained in memory. It is also recommended that the Model Name

Entry function be used in conjunction with each model setup. Another very useful function of the Model Selection function is the ability to set one aircraft up several different ways. This is helpful when multi-task performance is desired.

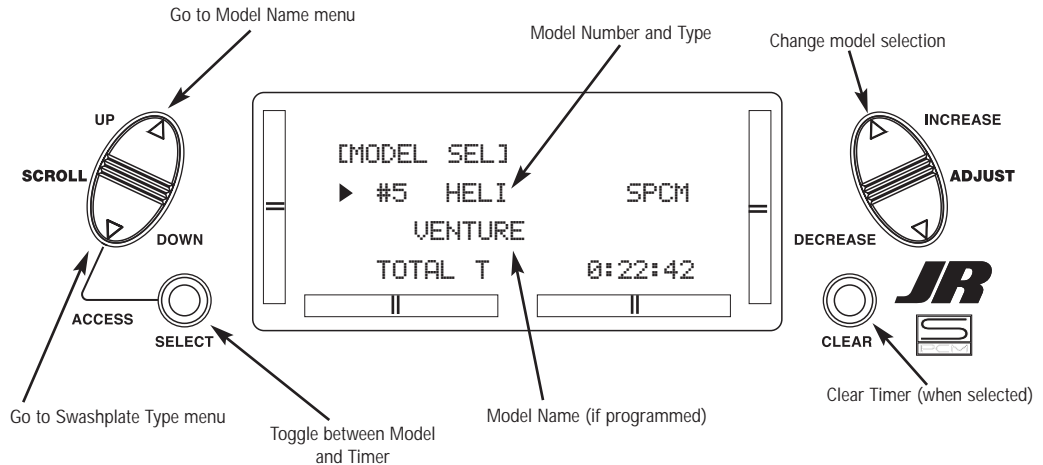

## Accessing the Model Select Function

1. While pressing the **Down** and **Select** keys, switch the transmitter to the *On* position to enter the Model Select mode.
2. Model Select will be displayed on the upper left portion of the LCD. If not, press the **Up** or **Down** key until **MODEL SEL** is displayed.
3. Pressing the (+) or (-) key will select among each of the ten models available. Notice that as each model is selected, its name appears in the LCD.
4. Once the desired model is displayed on the left, pressing the **Down** and **Channel** keys simultaneously will exit the Model Selection function and establish the model displayed as the new current model.
5. Press the **Select** key to select the timer function to clear the Total Timer. Press the **Clear** key to clear the Total timer.
6. Press the **Down** key to access the **SWASH TYPE** function.
7. Press the **Up** key to access the **MODEL NAME** function.
8. Press the **Down** and **Select** keys simultaneously to exit the **MODEL SEL** function.



The Swashplate Mixing function enables the XP6102 system to operate many different types of swashplate control systems, including 3 versions of CCPM.

### The Swashplate options are:

- 1 Servo: Non-CCPM, standard mixing type helicopter.
- 2 Servo/180° CCPM
- 3 Servo/120° CCPM (JR® style, most popular)
- 3 Servo/90° CCPM

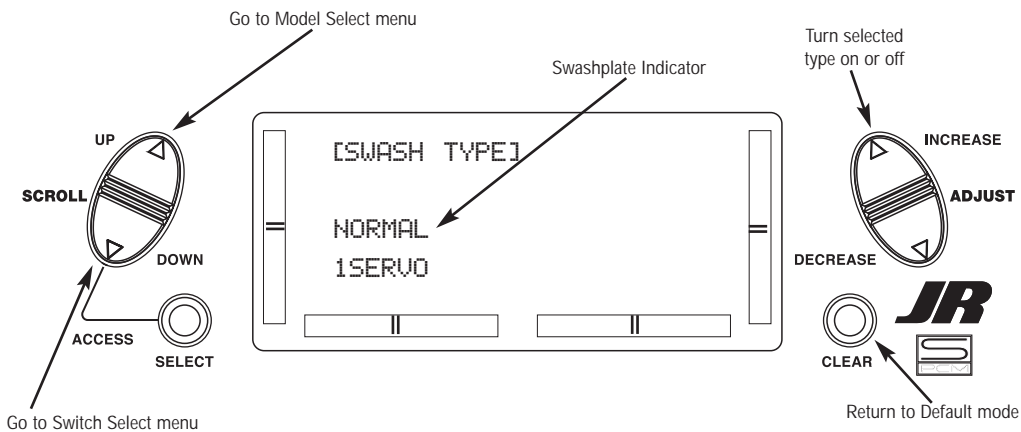

## Definition of Swashplate Types

1. While pressing the **Down** and **Select** keys, switch the transmitter to the *On* position to enter the system mode.
2. Press either the **Up** or **Down** key until **SWASH TYPE** is displayed in the upper center portion of the LCD.
3. Press the (+) or (-) keys to change the Swashplate type.
4. Pressing the **Clear** key will reset the Swashplate Type to the Normal position.
5. Press the **Up** key to access the **MODEL SELECT** function.
6. Press the **Down** key to access the **SWITCH SELECT** function.
7. Exit the **SWASH TYPE** function by pressing the **Down** and **Select** keys simultaneously.



The XP6102 allows the several options to be programmed for the dual rate, gear and flight mode switches.

Aileron and elevator dual rates can be programmed to be individually selected via it's own switch (Individ) or the aileron, elevator and rudder functions can be combined to operate from one of 4 switches.

The gear channel can be programmed to operate on one of 4 switched or rockers or it can be inhibited, helpful for some types of mixing. Plus the flight mode channel can be programmed to operate from switches or levers.

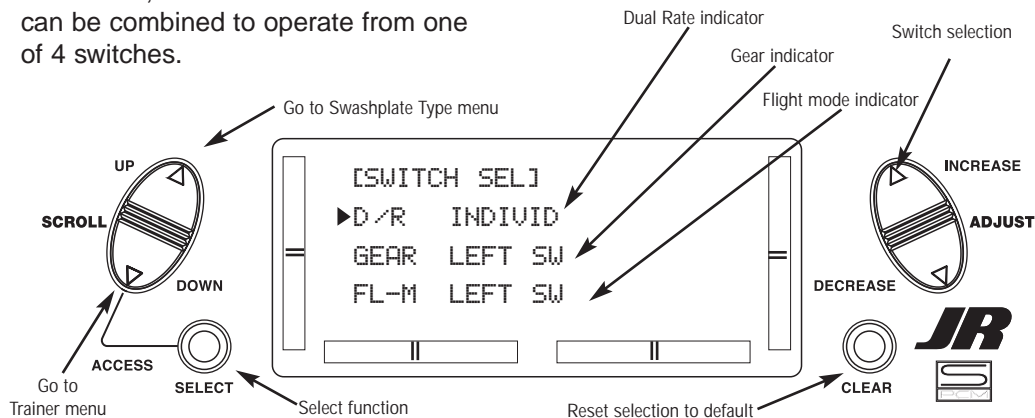

## Accessing the Modulation Function

### Dual Rates

D/R INDIVID (default) - In this mode the aileron and elevator rates are independently selected using the ELEV D/R and AILE D/R switches.

**Note:** In this mode the rudder D/R is always in the 0 position and is not selectable. This is the default setting.

COM AILE - In this mode the aileron, elevator and rudder dual rates are combined on the AILE D/R switch.

COM ELEV - In this mode the aileron, elevator and rudder dual rates are combined on the ELEV D/R switch.

COM R-SW - In this mode the aileron, elevator and rudder dual rates are combined on the upper right (flap) switch.

COM L-SW - In this mode the aileron, elevator and rudder dual rates are combined on the upper left (gear) switch.

### Gear Channel

LEFT SW (default) - The gear channel operates from the left upper (gear) switch.

AILE D/R - The gear channel operates from the aileron dual rate switch.

ELEV D/R - The gear channel operates from the elevator dual rate switch.

INHIBIT - The gear channel is inhibited and is centered making it useful as a slave channel for mixing.

RIGHT SW - The gear channel operates from the right upper (flap) switch.

### Flight Mode

LEFT SW (default) - The flight mode operates from the left upper (gear) switch.

AILE D/R - The flight mode operates from the aileron dual rate switch.

ELEV D/R - The flight mode operates from the elevator dual rate switch.

RIGHT SW - The flight mode channel operates from the right upper switch.



The XP6102 offers a programmable trainer function with three trainer options:

**Normal mode** - In this mode the transmitter acts as a conventional buddy-box system. The transmitter can be used as a slave or as a master: however in this mode, the reversing switches and trims must be adjusted so the slave transmitter matches the master transmitter. In normal mode, when the trainer switch is activated, the student has control of all functions and switches.

**Pilot Link** - When pilot link mode is used with the master transmitter, it allows the slave transmitter to be adjusted to factory defaults. The slave transmitter can simply be programmed in a model memory not being used and reset to factory defaults, thus preventing the need to synchronize the trims and reversing switches on the slave transmitter.

Also, when Pilot Link is used, the student only has control of the 4 basic channels (throttle, aileron, elevator, rudder) while the trainer (master) retains control of all other functions like gear, dual rate, programmed mixes, etc. This allows a pilot to have a test flight on a more complex airplane without having to remember complex switch positions.

**Pilot Link + Slave** - This mode is used only when the XP6102 is being used as a slave transmitter and the other Master transmitter has a Pilot Link program active. By selecting Pilot Link + Slave the transmitter is automatically in the correct programming mode to work as a slave in conjunction with another Pilot Link equipped transmitter.

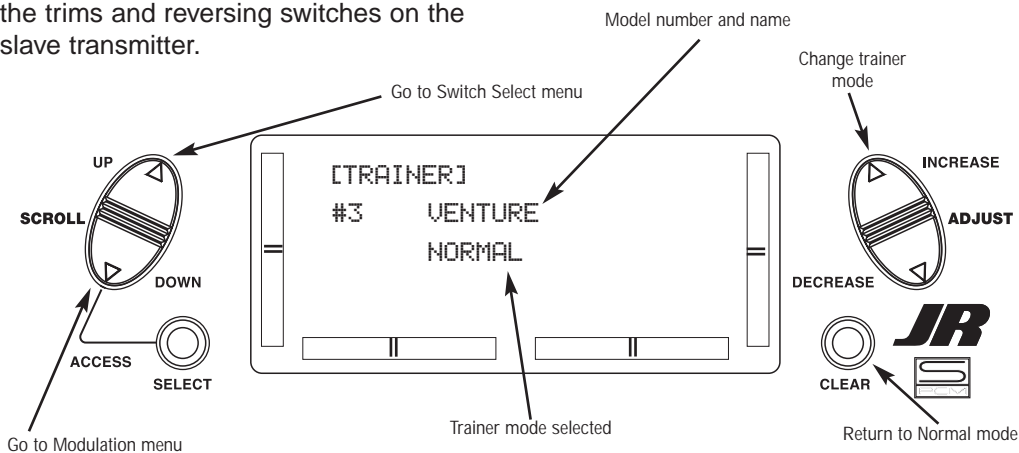

### Accessing the Trainer Function

1. Move the power switch to the *On* position while pressing the *Down* and *Select* keys to access the *System* mode.
2. Press either the *Up* or *Down* key until **TRAINER** appears at the top of the LCD.
3. Press either the (+) or (-) keys to change the Trainer Type type.
4. Pressing the *Clear* key will return the trainer function to the "normal" setting.
5. Press the *Down* key to access the **MODULATION** function.

6. Press the *Up* key to access the **SWITCH SEL** function.
7. To exit the **TRAINER** function, press the *Down* and *Select* keys simultaneously.

**Note:** The slave transmitter must always be in PPM modulation to operate.

Pilot Link + Slave automatically selects PPM modulation when activated.

When using other models of transmitters it will be necessary for the slave transmitter to be in PPM mode for the XP6102 to operate properly as a slave.



## 11G MODULATION SELECTION

The Modulation Selection function enables your XP6102 to transmit to a variety of JR® receivers. You can select from either S-PCM (Pulse Code Modulation) or from PPM (Pulse Position Modulation [FM]).

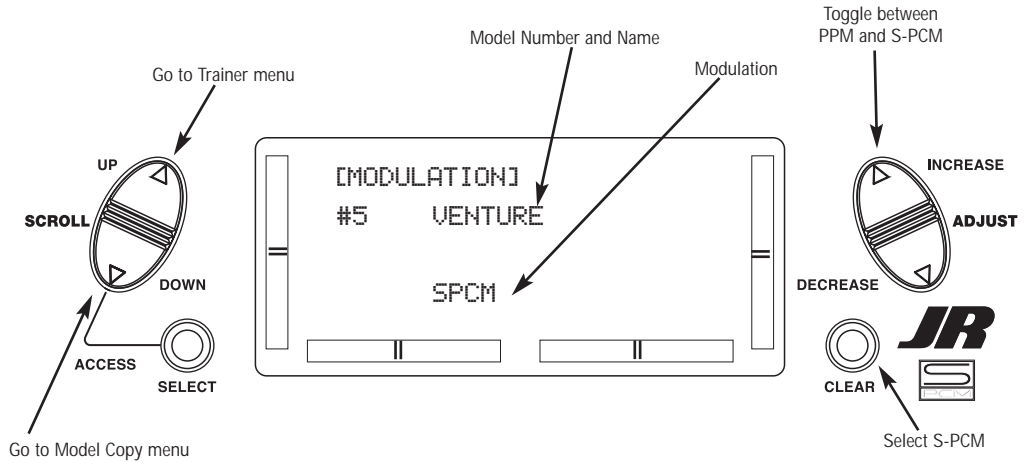

### Accessing the Modulation Function

1. Move the power switch to the *On* position while pressing the *Down* and *Select* key to access the System mode.
  2. Press either the *Up* or *Down* key until **MODULATION** appears at the top of the LCD.
  3. Press either the (+) or (-) keys to change the modulation type.
  4. Pressing the *Clear* key will also reset the modulation selection to the factory preset S-PCM.
  5. Press the *Down* key to access the **MODEL COPY** function.
  6. Press the *Up* key to access the **TRAINER** function.
  7. To exit the **MODULATION** function, press the *Down* and *Select* keys simultaneously.
- Note:** In the normal display, the selected modulation type will appear in the upper right of the LCD.



The Copy Selection function enables you to copy all of the settings of the current model to another model within the same transmitter. This is very useful when

setting up one aircraft several different ways or when trying an alternative setup for your current model.

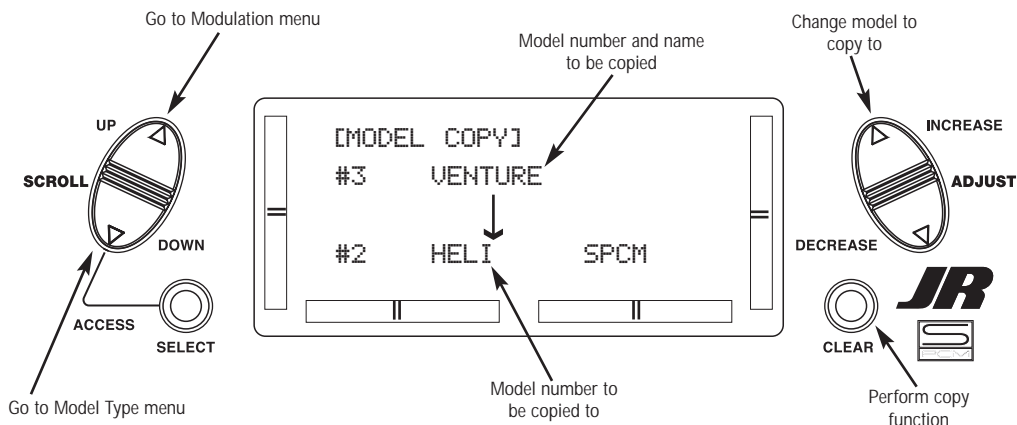

## Accessing the Model Copy Function

1. While pressing the **Down** and **Select** keys, move the transmitter's power switch to the *On* position.
2. Press either the **Up** or **Down** key until **MODEL COPY** appears on the top left of the LCD.
3. The upper number that appears is the current model. This is important to note as only the current model will be copied. Press the (+) or (-) keys to select the desired program (lower number) to copy the current model to.
4. Next, press the **Clear** key. The current model will then be copied to the selected model.

**Note:** Always make sure that the accepting model is either free of input or one which you no longer want to retain in your transmitter's memory. Once the copying process has been completed, the information of the accepting model is lost and the current model is input as the new data.

5. Press the **Up** key to access the **MODULATION** function.
6. Press the **Down** key to access the **MODEL TYPE** function.
7. Press the **Down** and **Select** keys simultaneously to exit the **MODEL COPY** function.



## 11.1 MODEL TYPE SELECTION

The XP6102 is capable of performing as a helicopter or airplane radio with full functions for each.

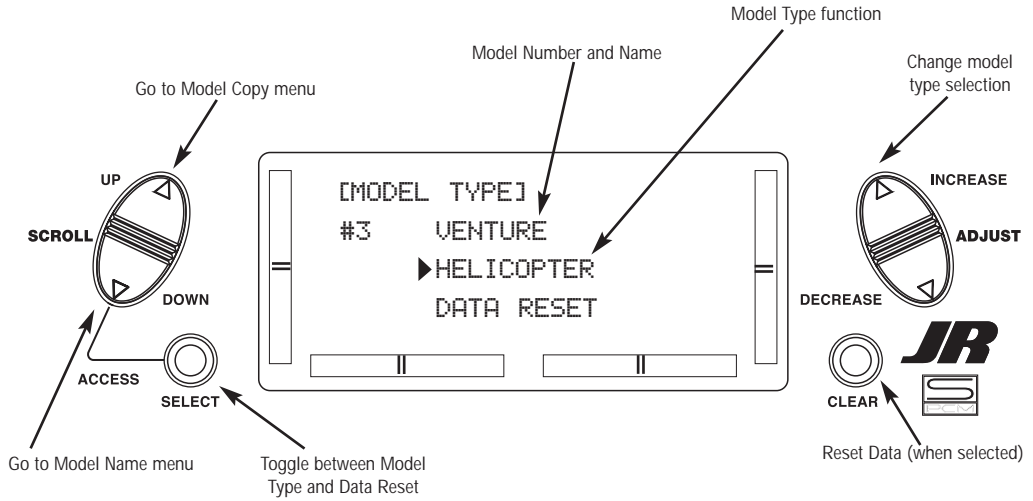

### Accessing the Type Selection Function

1. While pressing the *Down* and *Select* keys, switch the transmitter to the *On* position to enter the Model Setup mode.
2. Press either the *Up* or *Down* keys until **MODEL TYPE** is displayed in the left portion of the LCD.
3. Pressing either the (+) or (-) key will change the type of model.
4. Press the *Select* key to move the cursor to the Data Reset position.
5. Press the *Clear* key to reset the memory to the factory defaults.
6. Press the *Down* key to access the **MODEL NAME** function.
5. Press the *Up* key to access the **MODEL COPY** function.
6. Press the *Down* and *Select* keys simultaneously to exit the **MODEL TYPE** function.



The XP6102 allows an 8-digit name to be input for each of the ten models available. The current model will be displayed in the Normal display.

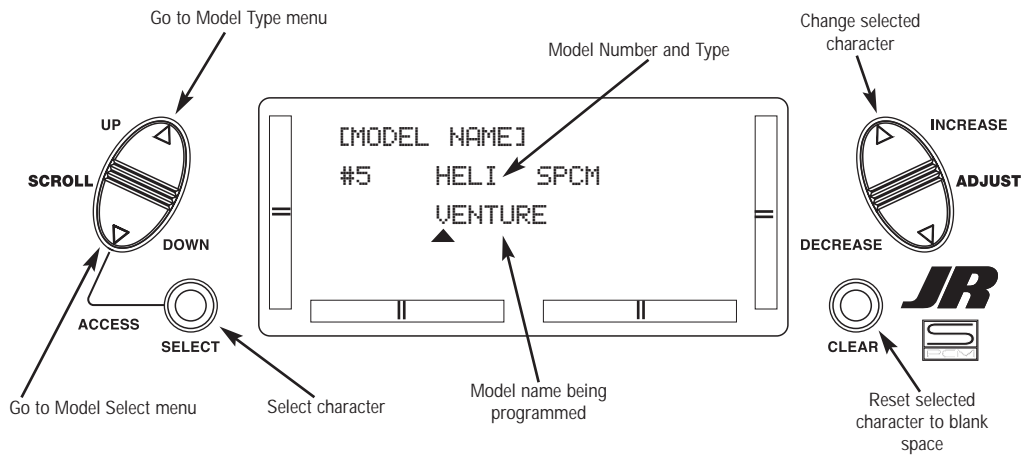

## Accessing the Model Name Entry Function

1. While pressing the **Down** and **Select** keys, switch the transmitter to the **On** (upper) position to enter the Model Setup mode.
2. Press the **Up** or **Down** key until **MODEL NAME** is displayed.
2. Press either the **Up** or **Down** key to select the first character for the model name.
4. Press the **Select** key to advance the character selection to the next character.
5. Repeat this procedure until all eight characters have been selected.
6. Press the **Down** key to access the **MODEL SEL** function.
7. Press the **Up** key to access the **MODEL TYPE** Selection function.
8. Press the **Down** and **Select** keys simultaneously to exit the **MODEL NAME** function.





To enter the Function mode, switch the transmitter power switch to the *On* position. Press the *Down* and *Select* keys simultaneously, and the display will show the last active program. Pressing either the *Up* or *Down* key then scrolls through the functions one by one, according to the Function Mode Flowchart shown below. Once the appropriate function is displayed, changes can be made by pressing the (+) or (-) keys. To select another channel of a particular function,

press the *Select* key. The Function mode is the most often used system to input data.

### Function Mode Flowchart

Information pertaining to each function is explained on the page listed next to the function name. Functions will appear in the same order they are shown on this chart.

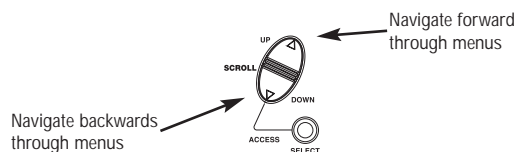
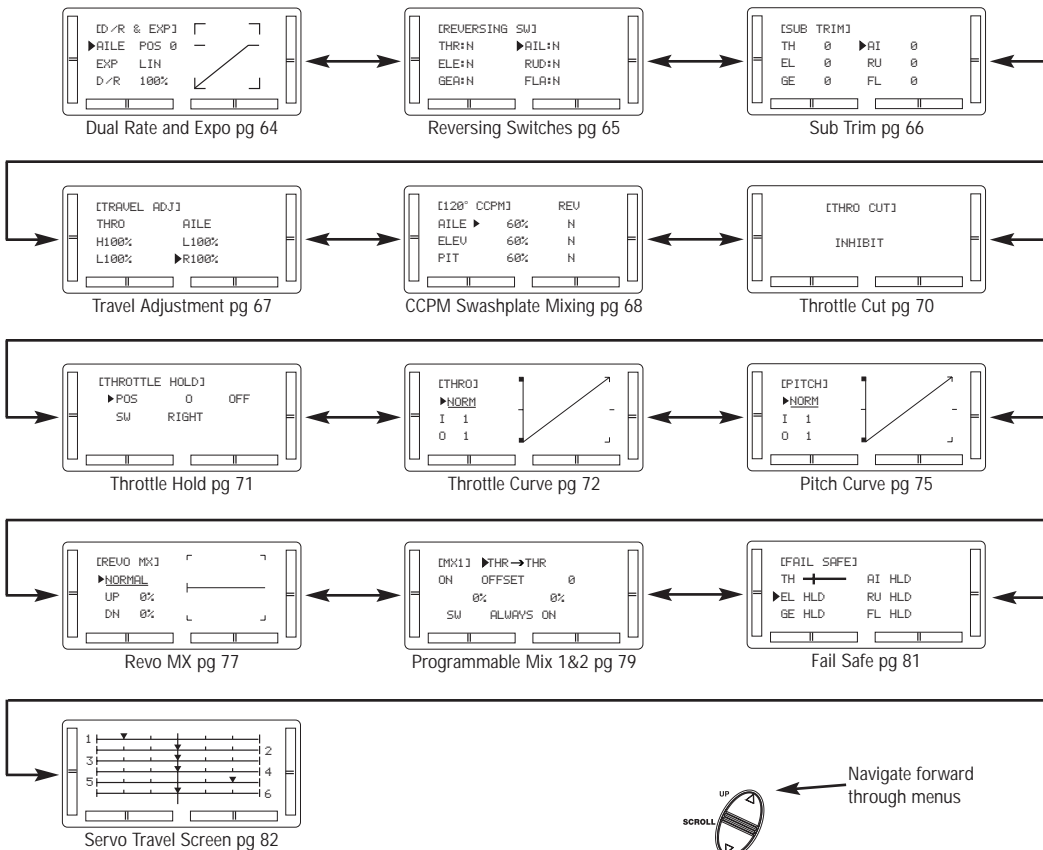

### Accessing the Mode Function

1. Move the power switch to the *On* position.
2. Press the *Down* and *Select* keys simultaneously.
3. Use either the *Up* or *Down* to scroll through the menu and access the applicable function.



Dual rates are available for the aileron, elevator and rudder channels of your RC aircraft. The combined Dual Rate Function is discussed on Page 24 - Switch Select. Dual rates may be defined as the ability to vary the travel or throw rate of a servo from a switch. Due to the differing travel rates, you will find that the sensitivity of the control either increases or decreases accordingly. A higher rate, or travel, yields a higher overall sensitivity. You may find it easier to think of the Dual-Rate function as double-rates or half-rates.

Exponential reduces the sensitivity in the middle portion of stick movement, while still allowing full travel at the end of the stick movement. The end result (travel) remains the same, although exponential changes the rate at which it achieves this travel. The adjustable range is from 0-100%. Zero percent (0%) is linear stick control, meaning the response rate is equal throughout the stick control. 100% is full exponential. The larger the exponential value, the less servo action or sensitivity you will notice around the neutral setting.

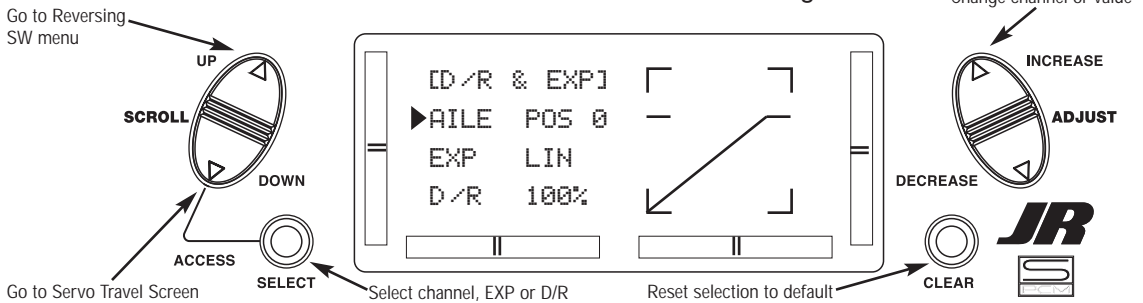

The amount of travel is adjustable from 0–125% in 1% increments. The factory setting, or default value, for both the 0 and 1 switch positions is 100%.

Either switch position may be selected as the low or high rate by placing the switch in the desired position and adjusting the value accordingly.

## Accessing the Dual Rate and Exponential Function

1. Place the transmitter power switch in the **On** position.
2. Access the Function mode by pressing the **Down** and **Select** keys simultaneously.
3. Press either the **Up** or **Down** key until **D/R & EXP** appears in the upper left corner of the LCD.
4. Press the **(+)** or **(-)** key until the desired channel (aileron, elevator or rudder) appears.
5. Select the switch position for which you want to adjust the rate. The number to the upper right of the current rate value on the display indicates the current position of the Dual-Rate switch for the channel that you have selected. Either a 0 or a 1 will be shown, corresponding to the position of the switch. To select the opposite switch position, move the appropriate Dual-

Rate switch to the opposite position.

The number that appears above the current rate value reflects the change.

6. Adjust the rate for the channel and the switch position just selected. To decrease the throw rate, move the cursor to the D/R position using the **Select** key, then press the **(-)** key. To increase the throw rate, press the **(+)** key. As stated previously, the adjustable rate is from 0-125% for each switch position and channel.
7. Press the **Up** arrow key to access the **REVERSING SW** menu.
8. Press the **Down** arrow key to access the **SERVO TRAVEL SCREEN**.
9. Press the **Down** arrow and **Select** keys simultaneously to exit the **DUAL RATE AND EXPONENTIAL** mode.



The Reverse Switch function is an electronic means of reversing the throw of a given channel (servo). All six

channels of the XP6102 offer reversible servo direction. This will ease setup during the servo installation into your helicopter.

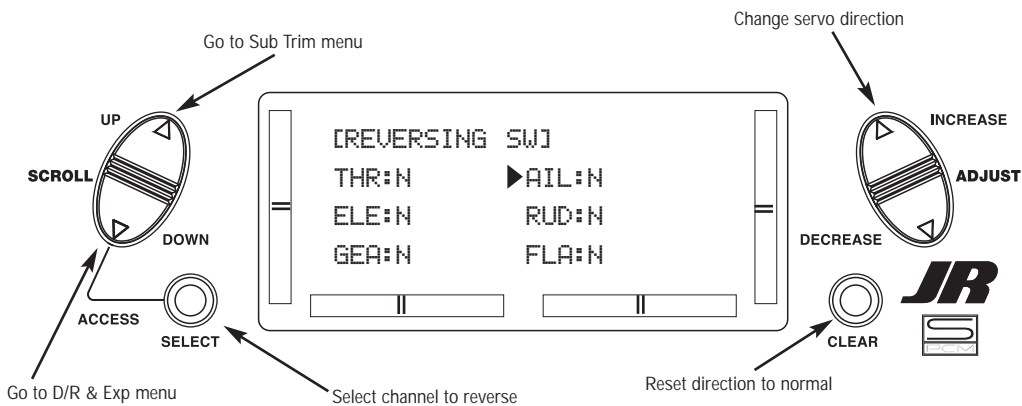

## Accessing the Servo Reversing Function

1. Place the transmitter switch in the *On* position.
2. Access the Function mode by pressing the *Down* and *Select* keys simultaneously.
3. Press either the *Up* or *Down* key until the **REVERSING SW** appears in the upper portion of the LCD.
4. Using your transmitter's control sticks, switches and potentiometers, move the control surfaces of your aircraft. Note the travel direction of each of the corresponding control surfaces.
5. After determining which channel(s) need to have the throw directions reversed, use the *Select* key to call up the appropriate channel.
6. Press either the (+) or (-) keys to change the travel direction of the servo. Pressing the *Clear* key returns the travel direction to Normal.
7. You can observe the change in the travel direction by moving the appropriate control at this time.
8. Access the **D/R & EXP** function by pressing the *Down* key.
9. Access the **SUB TRIM** function by pressing the *Up* key.
10. Exit the **SERVO REVERSING** function by pressing the *Down* and *Select* keys simultaneously.



The Sub Trim Adjustment function allows you to electronically fine-tune the centering of your servos. Individually adjustable for all six channels with a range of  $\pm 125\%$  ( $\pm 30$  degrees servo travel).

The sub trim functions provide precise servo arm neutral positioning if rotating the servo arm will not allow the desired servo arm position.

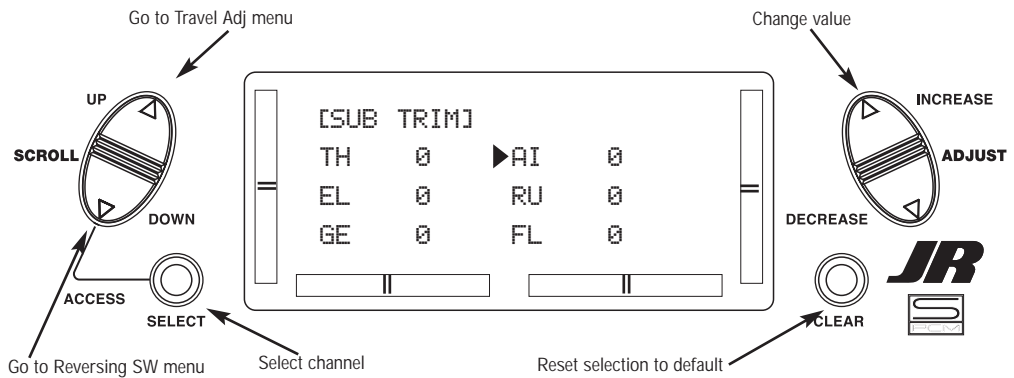

## Accessing the Sub Trim Function

1. Place the transmitter power switch in the *On* position.
2. To Access the Function mode, press the *Down* and *Select* keys simultaneously.
3. Press either the *Up* or *Down* key until **SUB TRIM** appears in the upper middle portion of the LCD.
4. Press the *Select* key until the desired channel appears.
5. Press the (+) or (-) key to establish the desired amount and direction of Sub-Trim.

**Caution:** Do not use excessive sub-trim adjustments since it is possible to overrun your servo's maximum Sub Trim. Remember that it is a trim convenience function. It is not intended to take the place of the proper mechanical trim adjustments that are necessary on any RC model.

6. Access the **REVERSING SW** function by pressing the *Down* key.
7. Access the **TRAVEL ADJ** function by pressing the *Up* key.
8. Exit the **SUB TRIM** function by pressing the *Down* and *Select* keys simultaneously.



The purpose of Travel Adjust is to offer you precise servo control deflection in either direction of servo operation. The XP6102 offers travel adjust for all six channels. The Travel Adjust range is from

0–150% (0 degrees to 60 degrees) from neutral, or center, and it can be adjusted for each direction individually. The factory default (Data Reset) value is 100% for each direction of servo travel.

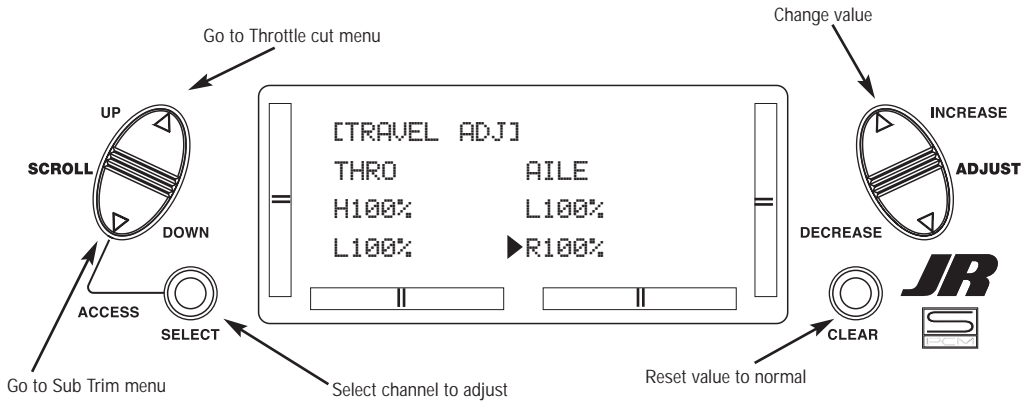

## Accessing the Travel Adjust Function

1. Place the transmitter power switch in the *On* position.
2. Access the Function mode by pressing the *Down* and *Select* keys simultaneously.
3. Press either the *Up* or *Down* key until **TRAVEL ADJ** appears in the upper portion of the LCD.
4. Press the *Select* key until the desired channel is highlighted.
5. Move the appropriate control stick (lever, switch, etc) to the right or left of center to the direction of travel you want to adjust. An arrow to the left of the travel adjust value will reflect the current position to be adjusted.
6. After the control stick or switch is placed in the direction of travel to be adjusted, press the (+) or (-) key until the proper amount of servo travel is shown on the LCD. Press the (+) key to increase the amount of servo travel. Press the (-) key to decrease the amount of servo travel.
7. Follow the same procedure for the remaining channels.
8. Access the **SUB TRIM** function by pressing the *Down* key.
9. Access the **THROTTLE CUT** function by pressing the *Up* key.
10. Exit the **TRAVEL ADJ** function by pressing the *Down* and *Select* keys simultaneously.



**Note:** The CCPM Swashplate Mixing screen is only displayed when Swashplate types 2Serv, 3Serv or 4Serv CCPM are selected in the Swashplate type Selection in System Mode.

The CCPM Swashplate Mixing Function (Cyclic Collective Pitch Mixing) of the XP6102 is designed to be used in model helicopters that utilize 2-servo (180°), 3-servo (120°) and 3-servo (90°) type swashplate control system.

The desired swashplate mixing type must first be selected at the Swash Type Selection in System Mode.

**If the Swashplate Type option has not been selected, proceed to Throttle Cut section.**

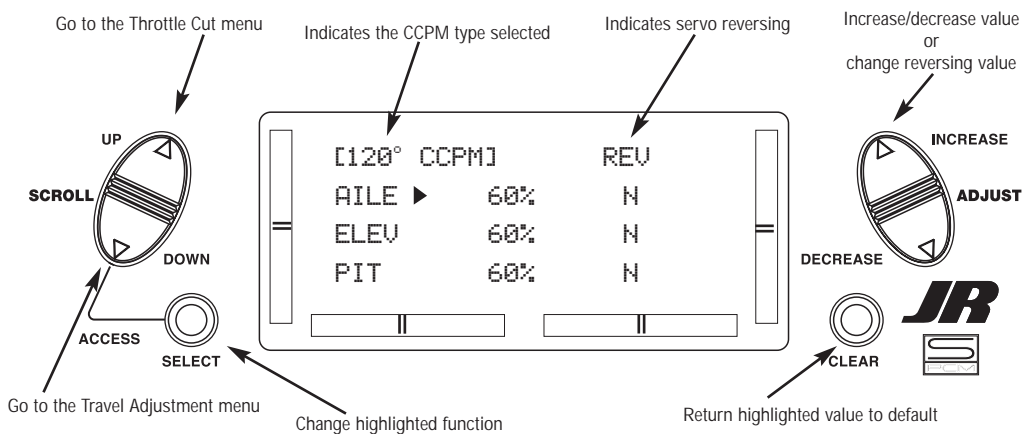

Screen showing 120° CCPM Swashplate selection

## Accessing the Swashplate Type

1. Place the transmitter power switch in the *On* position.
2. Access the Function Mode by pressing the *Down* and *Select* keys simultaneously.
3. Press either the *Up* or *Down* key until 90° CCPM, 120° CCPM or 180° CCPM appears in the middle left portion of the LCD.
4. Press the *Select* key until the desired function is highlighted.
5. Press the (+) or (-) Keys to Increase or Decrease the CCPM Values.
6. Follow the same procedure for the remaining channels.
8. Access the **TRAVEL ADJ** function by pressing the *Down* key.
9. Access the **THROTTLE CUT** function by pressing the *Up* key.
10. Exit the **CCPM SETUP** screen by pressing the *Down* and *Select* keys simultaneously.



CCPM is a type of pitch mixing where the two or three servos are connected directly to the swashplate of the

helicopter and physically move together and independently for all changes in pitch/cyclic. Please refer to the diagram below.

### CCPM Servo Variations

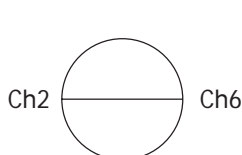

2 Servo/ 180° CCPM

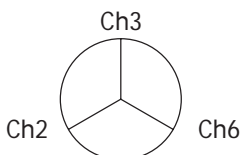

3 Servo/120° CCPM  
(JR style, most popular)

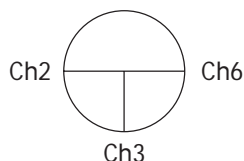

3 Servo/90° CCPM

#### 1). One servo (Standard Mechanical Mixing)

The most common form of Swashplate Mixing. This type uses each of the three servo to move the swashplate individually for pitch, Aileron, and Elevator changes. If one servo (NORM) is selected in the System Mode (Factory Default), the Swashplate Type Function will not appear on the LCD screen in this section.

#### 2). Two servo (180-degrees)

Two servos are used to move the swashplate, and are spaced at 180 degrees apart. This is not a very common control system configuration.

#### 3). Three servo (120-degrees)

Three servos are used to move the swashplate, and are spaced at 120 degrees apart. This is the most common form of CCPM, and is found in JR® and other brands of Helicopters.

#### 4). Three servo (90-degrees)

Three servos are used to move the swashplate, and are spaced at 90 degrees apart. This is also not a very common control system configuration.

#### CCPM Servo Connection/ Channel Numbers

##### 2 servo (180°)

Ch2 = Aileron  
Ch2 = Elevator  
Ch6 = Pitch

##### 3 servo (120°)

Ch2 = Aileron  
Ch3 = Elevator  
Ch6 = Pitch

##### 3 servo (90°)

Ch2 = Aileron  
Ch6 = Pitch



## 12G THROTTLE CUT SWITCH

This function assigns the Throttle Cut switch to the push button located on upper right front of the transmitter. The Throttle Cut function is designed to return the throttle trim to the lowest

position instantly and keep this position while the button is pressed. This feature is used to “cut” or stop the engine without changing the position of digital throttle trim.

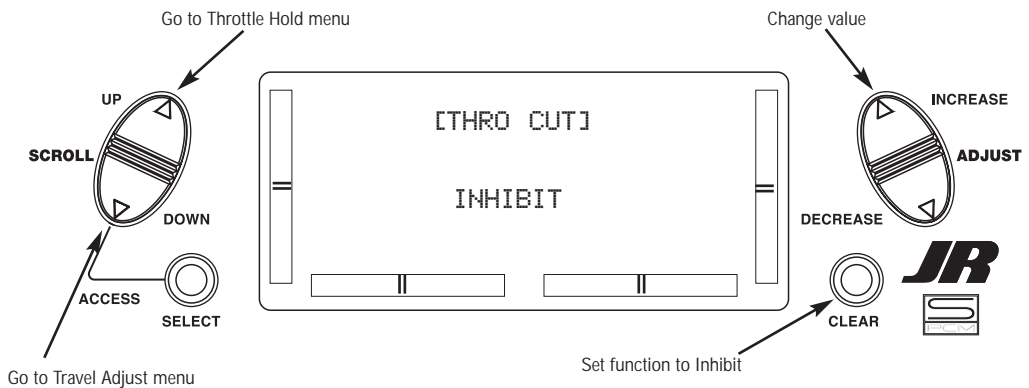

### Accessing the Throttle Cut Function

1. Place the transmitter power switch in the *On* position.
2. Access the Function mode. To do so, press the *Down* and *Select* keys simultaneously. Press either the *Up* or *Down* key until **THRO CUT** appears in the upper portion of the LCD screen.
3. Use the (+) and (-) keys to change the value of the Throttle cut function.

**Note:** Pressing the *Clear* key will Inhibit the Throttle Cut, turning it off until it has been reactivated.

4. Access the **TRAVEL ADJ** mixing function by pressing the *Down* key.
5. Access the **THROTTLE HOLD** function by pressing the *Up* key.
6. Exit the **THRO CUT** function by pressing the *Down* and *Select* keys simultaneously.



The Throttle Hold function is designed to hold the throttle servo in a specific position during an autorotation. This is very useful for practicing autorotation

landings. The throttle hold switch can be programmed to one of the four toggle switches. Throttle hold will always be "On" in the forward switch position and "Off" in the rear position.

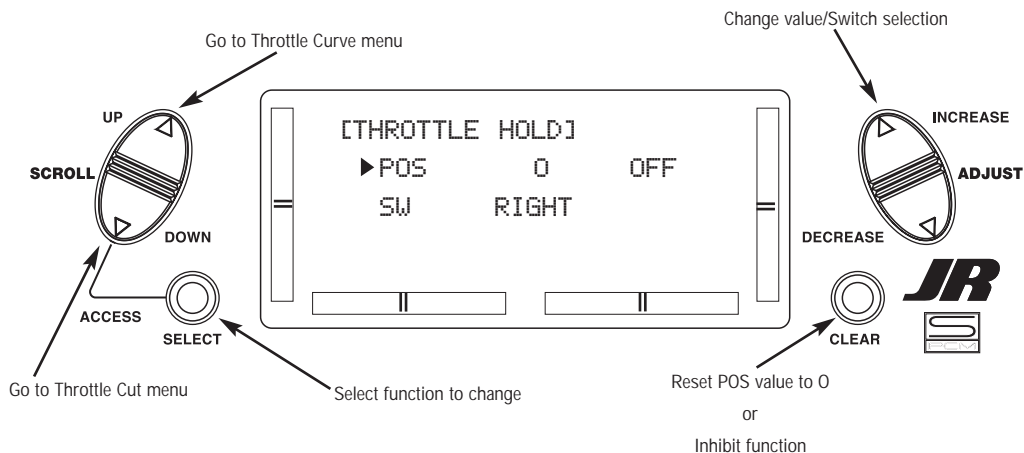

### Accessing the Throttle Hold Function

1. Place the transmitter switch in the *On* position.
2. Press the *Down* and *Select* keys simultaneously to enter the Function mode.
3. Press either the *Up* or *Down* key until **THROTTLE HOLD** appears across the top of the LCD.
4. The factory setting for the throttle hold is inhibit. Pressing either the (+) or (-) key will activate Throttle Hold and display the current throttle hold value.
5. Using the (+) or (-) key, adjust the throttle hold value to deliver the proper engine idle rpm for your helicopter. The adjustable range is (-20%+50%). Once you establish the proper idle value for

your engine, you can use this value for throttle hold as well. To shut the engine off for autorotation, a negative or zero value should be input.

**Note:** When the throttle hold is activated, and the switch is on, the indicator on the LCD will change from Off to On. In addition, the throttle trim indicator will be inhibited.

6. Access the **THROTTLE CURVE** function by pressing the *Up* key.
7. Access the **THROTTLE CUT** function by pressing the *Down* key.
8. To exit the **THROTTLE HOLD** function, press the *Down* and *Select* keys simultaneously.



The XP6102 offers two (2) separate throttle curves with five adjustable points per curve. This function allows you to customize the throttle curve and pitch curve together to maximize engine performance at a particular pitch setting. Once the throttle curves are established, each can be activated in flight using the two (2) position flight mode switch.

The flight mode switch offers two selectable ranges: Normal and Stunt. The Normal position should be used as the hover throttle curve. The Stunt position should be used for aerobatic maneuvers and forward flight.

**Note:** The throttle trim and hovering throttle levers are only operable when the flight mode switch is in the normal position. Thus, in normal function it will have no effect. Also, adjusting the hovering throttle lever and throttle trim has no effect on the input values of the throttle curve.

Each of the five points of the throttle curve are independently adjustable from 0–100%. These five points correspond to the position of the throttle stick. The illustration below shows the normal throttle curve setting for the dead slow position with throttle trim at default.

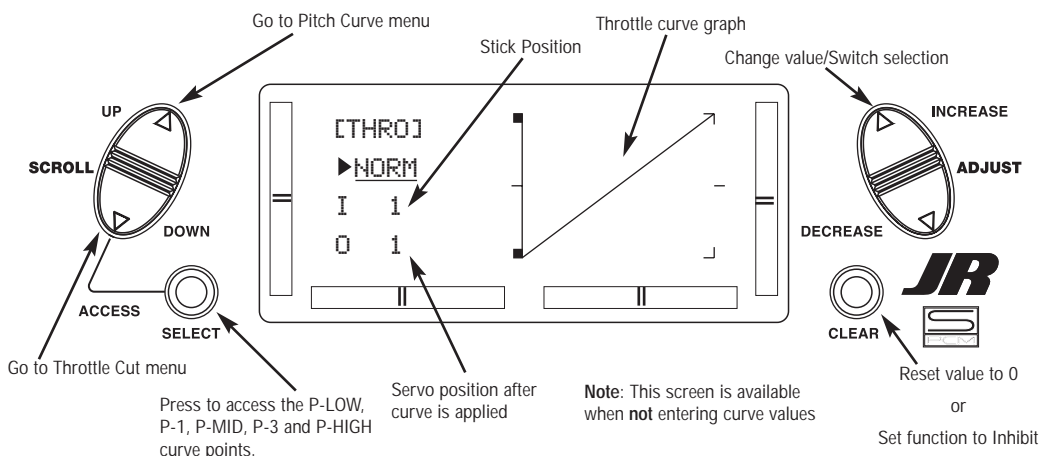

The transmitter is factory preset to the throttle curve as indicated by the solid line in the figure at right. Individual middle points can be increased or decreased to suit your specific needs.

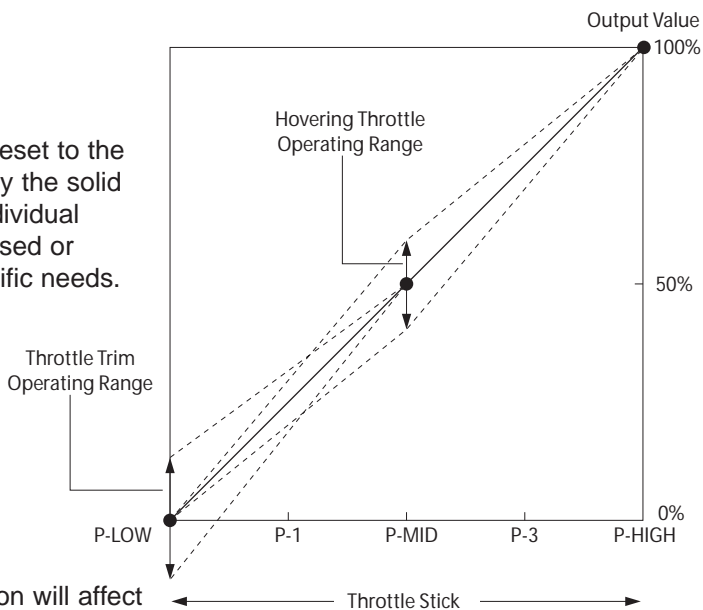

The throttle trim lever position will affect the low-point position as shown when in the Normal mode Throttle Curve.



1. Place the transmitter switch in the *On* position.
  2. Press the *Down* and *Select* keys simultaneously to enter the Function Mode.
  3. Press either the *Up* or *Down* key until **THRO** appears in the upper portion of the LCD.
- Note:** Use **NORM** for hover curves and **STUNT** for aerobatics. We will concentrate on the hovering curve during this example.
4. Press the *Select* key to select the point of the curve you want to change.
  5. Press either the (+) or (-) key to change the value of the current curve point.  
The range of each point is 0–100% in .5% intervals.

**Note:** In each curve, the factory setting indicates **INH** for points 1 and 3. These values are 25% and 75% respectively if no value changes are made to any other points. If any of

the other points have been changed while these points were inhibited, the inhibited points will also change to plot a smooth curve. If you want to keep this from happening, press the *Select* key until the display indicates **P-1** or **P-3** at the upper right portion of the LCD. Press either the (+) or (-) key to activate the points 1 (25%) or 3 (75%). The values for each of these curves can then be fully adjusted by pressing either the (+) or (-) key.

6. To set curves for **STUNT** mode, press the *Select* to highlight the **NORM** function, then press the (+) or (-) key to select the **STUNT** function. Repeat Steps 4 and 5 to complete the procedure.
7. Access the **PITCH CURVE** function by pressing the *Up* key.
8. Access the **THROTTLE HOLD** function by pressing the *Down* key.
9. Exit the **THROTTLE CURVE** function by pressing the *Down* and *Select* keys simultaneously.

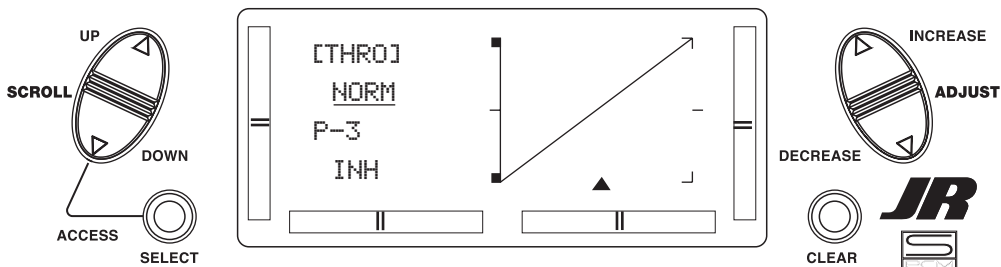

Screen showing setting the Mid-Point of the Normal Throttle Curve

## Throttle Time Settings

The throttle trim lever is only active when the flight mode switch is in the normal position. The throttle trim is used to increase or decrease the engine power when the flight mode switch is in the Normal mode. The throttle trim lever has no effect on positions 1 or throttle hold.

**Note:** Making changes to the throttle trim lever does not change the input values for any of the points on the throttle curve; it merely makes adjustments to the engine idle speed position.

## Hovering Throttle Lever Settings

The Hovering Throttle lever increases or decreases the engine output power for the middle three points set for the throttle curve. As shown in the figure below, use of the hovering throttle lever shifts the curve upward or downward parallel with

the original curve. Therefore, operation of the hovering throttle knob does not cause any change to the original settings of the throttle curve.

The throttle trim range will affect the throttle curve as shown.

The adjustable range of output using the hovering throttle lever is approximately +/-9%.

**Note:** The Hovering Throttle has no effect on flight mode switch position 1.

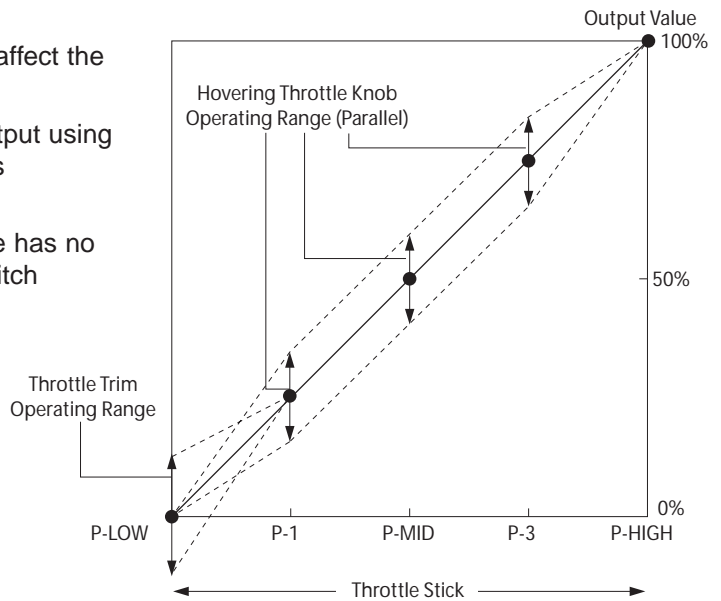

Adjustment of the pitch curve is very similar to the throttle curve adjustment described in the preceding section. A thorough understanding of the Throttle Curve Section will make pitch curve adjustment easier to understand.

There are three independent types of pitch curves available: Normal, Stunt, and Hold. Each pitch curve contains five adjustable points: LOW, 1, MID, 3 and HIGH.

**Note:** The pitch curve for the Throttle Hold function can only be set if this system is activated.

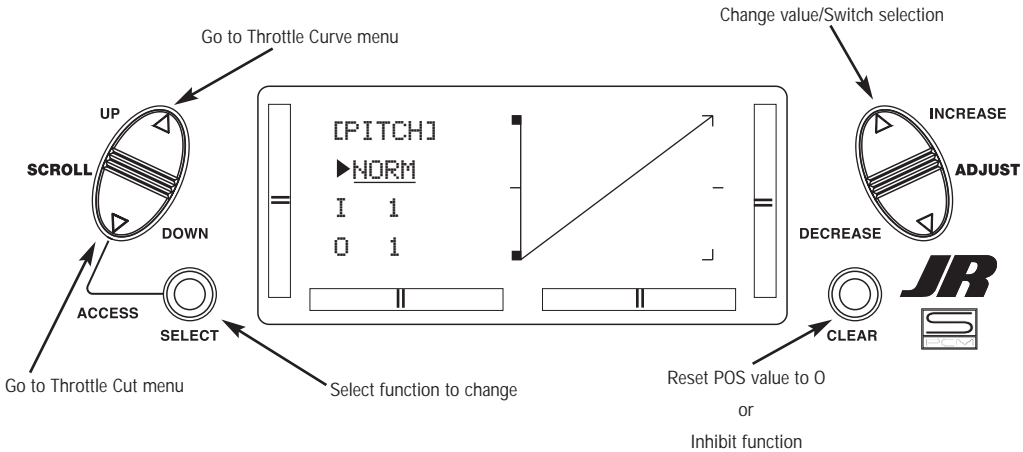

## Accessing the Pitch Curve Function

1. Place the transmitter switch in the *On* position.
2. Press the *Down* and *Select* keys simultaneously to enter the Function mode.
3. Press either the *Up* or *Down* key until **PITCH** appears in the top of the LCD.

**Note:** Use **NORMAL** for hover curves and **STUNT** for stunt curves. We will concentrate on the hovering curve during this example.

4. Press the *Select* key to select the point of the curve you want to change.
5. Press either the (+) or (-) key to change the value of the current curve point. The range of each point is 0–100% in .5% intervals.

**Note:** In each curve, the factory setting **INH** indicates Inhibited for points 1 and 3. These values are 25% and 75% respectively, if no value changes are made to any other points. If any of the other points have been changed while these points

were inhibited, the inhibited points will change to plot a smooth curve. If you want to keep this from happening, press the *Select* key to display the positions 1 and 3, then press the (+) or (-) key to activate each point.

6. To set curves for **STUNT** mode, press the *Select* to highlight the **NORM** function, then press the (+) or (-) key to select the **STUNT** function. Repeat Steps 4 and 5 to complete the procedure.
7. To set the curves for the Throttle Hold mode "H", press the *Up* key once again until "H" is displayed, and repeat steps 4 and 5.
8. Access the **REVO MX** function by pressing the *Up* key.
9. Access the **THROTTLE CURVE** function by pressing the *Down* key.
10. Exit the **PITCH CURVE** function by pressing the *Down* and *Select* keys simultaneously.



## Hovering Pitch Lever

The Hovering Pitch lever operates in the same manner as the Hovering Throttle lever. It is only operable while the flight mode switch is in the NORMAL position, and its function is to shift the middle portion of the curve upward or downward.

### Example of Throttle Curve and Pitch Curve Settings

An example of throttle curve and pitch curve settings for aerobatic specifications is shown below in the form of graphs. Details of the curves will differ depending on the helicopter specifications. In these examples, the throttle open-close stroke and autorotation pitch stroke are set 0 to 100 to ease your understanding of other curves.

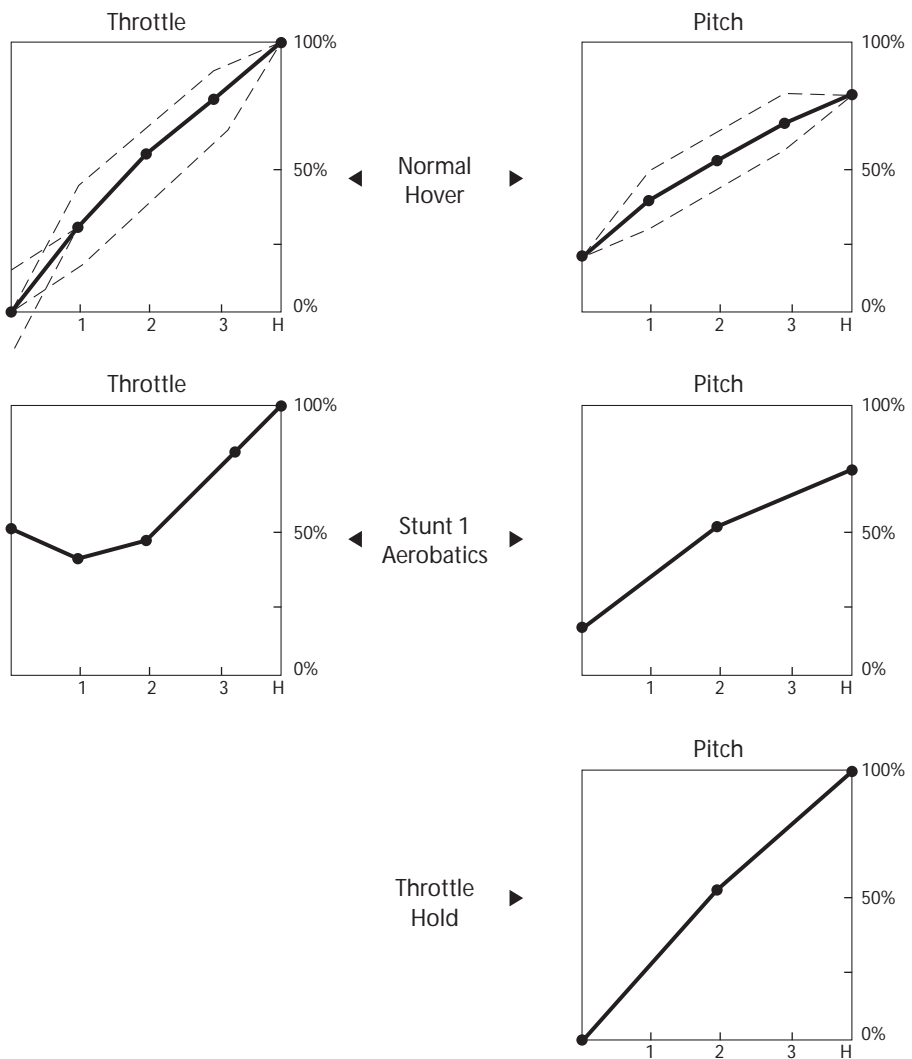

The Revolution Mixing function mixes tail rotor with the Throttle and Pitch Curve functions to counteract torque from the main rotor blades. When set up correctly, the helicopter should climb and descend without a tendency to yaw in either direction. Because torque reaction varies with different power settings, it is necessary to vary the tail rotor pitch at the same time. The XP6102 offers two

separate revolution mixing programs, with independent up and down mixing for each — one for Flight mode position Normal and the other for Stunt. The up mixing adjusts the tail rotor compensation for the mid to high throttle setting and the down mixing adjusts the tail rotor compensation for the mid to low throttle setting.

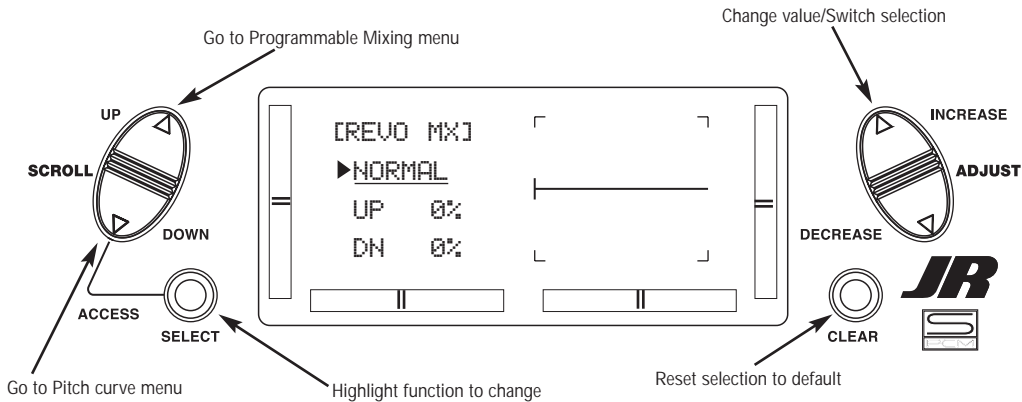

### Accessing the Revolution Mixing Function

1. Place the transmitter switch in the *On* position.
2. Press the *Down* and *Select* keys simultaneously to enter the Function Mode.
3. Press the *Up* or *Down* keys until **REVO MX** appears at the top of the LCD.
4. Pressing the *Select* key will highlight either the *Up* mix, *Down* mix, or the flight mode switch position. When the flight mode switch is in the displayed position and the throttle stick is in the displayed position, the flight mode will be underlined.
5. Press the (+) key to increase the right tail compensation or press the (-) key to increase the left compensation. Press the *Clear* key to reset to 0%.
6. This setup procedure can be used for revolution mixing for either flight mode switch position Normal or Stunt. The Stunt position should be used for forward and/or inverted compensation.
7. Access the **PITCH CURVE** function by pressing the *Down* key.
8. Access the **MX1** function by pressing the *Up* key.
9. Exit the **REVO MX** function by pressing the *Down* and *Select* keys simultaneously.



## Setting Up Revolution Mixing (non-heading lock gyros only)

---

Set up the helicopter so that it will hover with the tail rotor trim centered. Establish the helicopter into a stable hover, then steadily increase the throttle to initiate a steady climb. The body of the helicopter will move in the opposite direction to the main rotor rotation. Increase the U, or Up, setting until the helicopter climbs with no tendency to turn. At a safe altitude, close the throttle; the helicopter will descend and the body will turn in the

same direction as the main rotor rotation. Increase the D, or Down, mix until the helicopter descends with no tendency to turn. Throttle stick movements should be slow, and the initial acceleration and deceleration swings should be ignored.

The Acceleration Mixing function is provided to compensate for the main rotor acceleration (and deceleration) torque.



The XP6102 offers two programmable mixes to be used for any number of different purposes. This function allows mixing any one channel to any other channel. This mix can remain on at all times or be switched on and off in flight using a number of different switches.

Mix number 1 is of the standard variety, in that the digital trim for the master channel only affect the master channel, and not the slave channel. Mix number 2 is of the "Trim Include" variety. This mix is used any time the mix requires the slave channels trim position to be varied when the master channels digital trim position is varied.

Each channel of this radio is identified by an abbreviated name. The chart below indicates the channel and its corresponding abbreviation. The channel name appearing first is known as the "master channel" or the channel to which you want to mix. The second number is known as the "slave channel" or the channel that is being mixed into the master channel. For example, AIL → RUD would indicate aileron-to-rudder mixing. Each time the aileron stick is moved, the aileron will deflect, and the rudder will automatically move in the direction and to the value input.

Mixing is proportional, so small inputs of the master channel will produce small outputs of the slave channel. Each programmable mix has a mixing "offset." The purpose of the mixing offset is to re-define the neutral position of the slave channel.

- THR: Throttle
- AIL: Aileron
- ELE: Elevator
- RUD: Rudder
- GEA: Gear
- PIT: Pitch

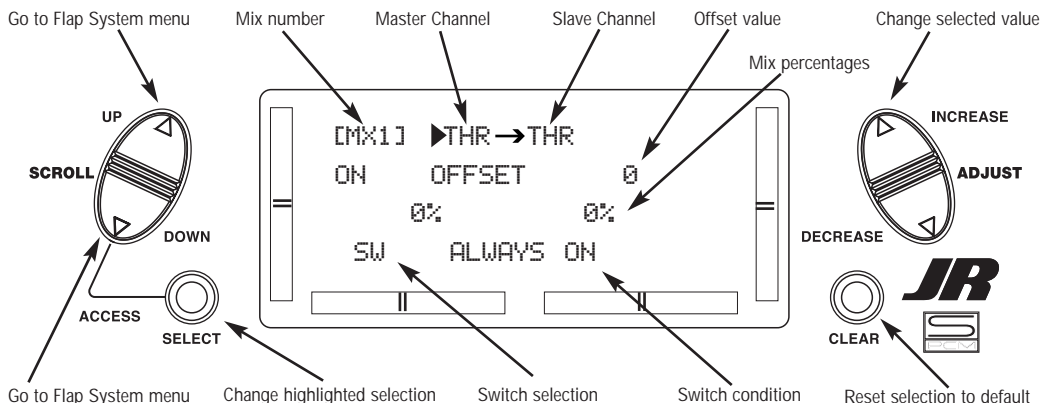

1. Place the transmitter switch in the *On* position.
2. Press the *Down* and *Select* keys simultaneously to enter the Function mode.
3. Press either the *Up* or *Down* key until **MIX 1** appears in the LCD.

### Selecting the Master and Slave Mixing Channels

4. Press the (+) or (-) keys to select the master channel.
5. Press the *Select* key to move the cursor to the slave channel position.
6. Press the (+) or (-) keys to select the slave channel.
7. Press the *Select* key once. The display will continue to show the current mixing channels at the top of the LCD, but now an arrow will indicate the current stick position (master) to be adjusted.

### Setting the Mixing Values

8. While holding the master stick in the direction you want to mix, press the (+) or (-) keys to increase or decrease the mixing value for the slave channel. The value in the LCD will change to display the current mix value selected. Next, hold the master stick to the other side to adjust the mix for the other direction.

### Setting the Mixing Switch Activation

9. Press the *Select* key until the SW is highlighted. The LCD with "ALWAYS ON" indicates the current switch that this mix is currently selected to always be active (ON).

### Mixing Operation and Switches

Each mixing program can be turned on and off by a lever or switch. The levers and switches that can be selected for program mixing are tabulated at the right with their abbreviations appearing on the display and their corresponding positions.

The mix switch options are:

ALWAYS ON  
RIGHT FWD  
RIGHT REA  
LEFT FWD  
LEFT REA  
AILE D/R  
ELEV D/R

### Setting the Mixing Channel Offset

1. Press the *Select* key until offset is highlighted. The display will show the current mixing channels at the top of the LCD, with the word "OFFSET" in the center of the LCD. The value to the right is the mixing Offset neutral point, currently 0.
2. A new value for the offset can be selected using the (+) or (-) keys. This is the new neutral point for the slave channel (Point that the mix is activated). Press the *Clear* key to reset the value back to 0.
3. Press the *Down* and *Select* keys simultaneously to exit the **Programmable Mix** function.

With a little practice, programmable mixing will become easier to understand. Mixing is only limited by your imagination.



The Fail Safe Function is available only when you use the XP6102 transmitter in PCM modulations. This function is designed to help minimize damage to your aircraft during a loss of signal to the receiver. The servos either assume the Fail Safe presets or hold their last good signal position.

As noted earlier, if you are in the PPM modulation, the Fail Safe Function is not applicable. Therefore, the Fail Safe Function will not appear on your LCD screen menu while in the PPM mode. Refer to the Modulation Selection section for more information pertaining to the broadcast signal of your XP6102 transmitter.

**Note:** The throttle Fail Safe position is defaulted to the idle position for added safety.

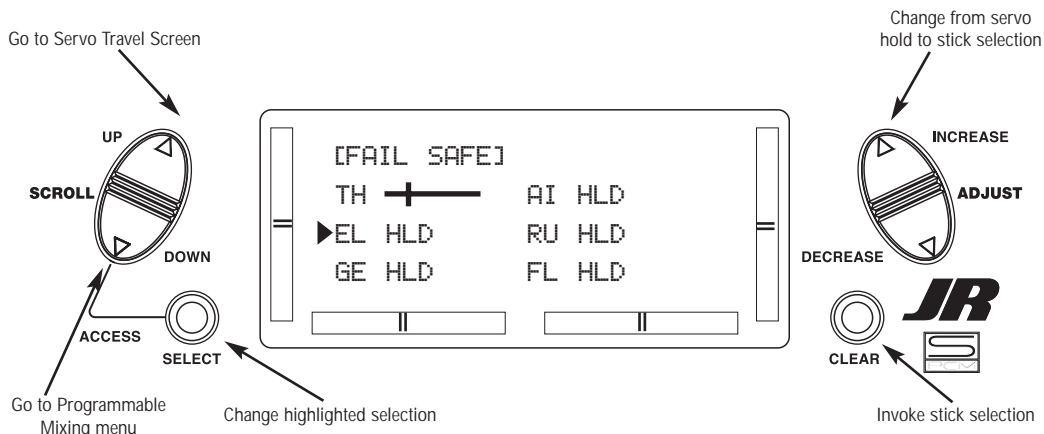

## Accessing the Fail Safe Function

1. Place the transmitter power switch in the *On* position.
2. Access the Function mode. To do so, press the *Down* and *Select* keys simultaneously. Press either the *Up* or *Down* key until **FAIL SAFE** appears in the upper portion of the LCD screen.
3. Use the *Select* key to highlight the servo function to set.
4. Use the (+) or (-) keys to toggle between servo hold or setting the servo position.
5. When using the servo setting position, move the corresponding control stick to the position where you want the servo if the radio enters into the fail safe mode. Press the *Clear* key to have the transmitter memorize the stick position.
6. Repeat steps 4 and 5 until all six controls have been set.
7. Access the **SERVO TRAVEL** screen by pressing the *Up* key.
8. Access the **MIXING FUNCTIONS** function by pressing the *Up* key.
9. Exit the **FAIL SAFE** function by pressing the *Down* and *Select* keys simultaneously.



The Servo Travel Screen is used to verify the stick movements of the transmitter.

It can also be used to verify the mixing functions have been performed correctly without the need to turn on the aircraft.

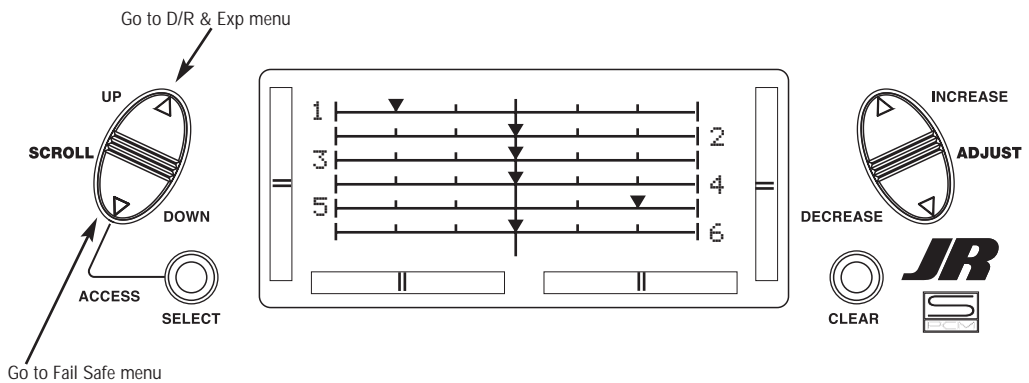

## Accessing the Servo Travel Screen

1. Place the transmitter power switch in the *On* position.
2. Access the Function mode. To do so, press the *Down* and *Select* keys simultaneously. Press either the *Up* or *Down* key until the **SERVO TRAVEL** screen appears.
3. Move the sticks. The the indicators correspond to the following:
4. Access the **D/R & EXP** screen by pressing the *Up* key.
5. Access the **FAIL SAFE** function by pressing the *Up* key.
6. Exit the **SERVO TRAVEL** screen function by pressing the *Down* and *Select* keys simultaneously.

Indicator 1:	Throttle
Indicator 2:	Aileron
Indicator 3:	Elevator
Indicator 4:	Rudder
Indicator 5:	Gear
Indicator 6:	Pitch



# XP6102 DATA SHEET – HELI

MODEL NAME \_\_\_\_\_

MODEL NUMBER \_\_\_\_\_

	THRO	AILE	ELEV	RUDD	GEAR	PITCH
REVERSE SW	R • N	R • N	R • N	R • N	R • N	R • N
SUB TRIM						
TRAVEL ADJUST	H %	L %	U %	L %	+ %	H %
	L %	R %	D %	R %	- %	L %
FAIL SAFE (PCM)						

THROTTLE CURVE		P-LOW	P-1	P-MID	P-3	P-HIGH	THROTTLE HOLD	ON • OFF	POSITION
	NORMAL								
	STUNT								

PITCH CURVE		P-LOW	P-1	P-MID	P-3	P-HIGH	MODULATION
	NORMAL						
	STUNT						

PPM • SPCM

SWASH TYPE	NORMAL	90° CCPM	120° CCPM	180° CCPM
------------	--------	----------	-----------	-----------

SWASH MIX	AILE	ELEV	PITCH	SWITCH SELECT	D/R	
	%	%	%		GEAR	
	REV R•N	REV R•N	REV R•N		FL-M	

PROGRAM MIX		CHANNEL	SW	+POS	-POS	OFFSET
	MIX 1	-		%	%	
	MIX 2	-		%	%	

DUAL RATE • EXPO	0	AILE	ELEV	RUDD	REVO MIX	NORMAL	UP	%
		D/R	%	%		%	DOWN	%
	EXP	%	%	%		STUNT	UP	%
	1	D/R	%	%			%	DOWN
		EXP	%	%		%		

NOTES:

Feel free to make photocopies of the data sheet for use with all your models.





- Do not lubricate servo gears or motors.
- Do not overload retract servos during retracted or extended conditions. Make sure they are able to travel their full deflection. Overloading or stalling a servo can cause excessive current drain.
- Make sure all servos move freely through their rotations and no linkages hang up or bind. A binding control linkage can cause a servo to draw excessive current. A stalled servo can drain a battery pack in a matter of minutes.
- Correct any control surface "buzz" or "flutter" as soon as it is noticed in flight, as this condition can destroy the feedback potentiometer in the servo. It may be extremely dangerous to ignore such "buzz" or "flutter."
- Use the supplied rubber grommets and brass servo eyelets when mounting your servos. Do not over-tighten the servo mounting screws, as this negates the dampening effect of the rubber grommets.
- Ensure the servo horn is securely fastened to the servo. Use only the JR® servo arm screws provided; the size is different from other manufacturers.
- Discontinue to use servo arms when they become "yellowed" or discolored. Such servo arms may be brittle and can snap at any time, possibly causing the aircraft to crash.
- Check all related mounting screws and linkages frequently. Aircraft often vibrate, causing linkages and screws to loosen.

## GENERAL NOTES

Radio controlled models are a great source of pleasure. Unfortunately, they can also pose a potential hazard if not operated and maintained properly. It is imperative to install your radio control system correctly. Additionally, your level of piloting competency must be high enough to ensure that you are able to control your aircraft under all conditions. If you are a newcomer to radio controlled flying, please seek help from an experienced pilot or your local hobby shop.

**Safety Do's and Don'ts for Pilots**

- Ensure your batteries have been properly charged prior to initial flight.
  - Keep track of the time the system is turned on so you will know how long you can safely operate your system.
  - Perform a ground range check prior to the initial flight of the day. See the "Daily Flight Checks Section" for information.
  - Check all control surfaces prior to each takeoff.
  - Use frequency flags.
  - Do not fly your model near spectators, parking areas or any other area that could result in injury to people or damage of property.
  - Do not fly during adverse weather conditions. Poor visibility can cause disorientation and loss of control of your aircraft. Strong winds can cause similar problems.
  - Do not fly unless your frequency is clear.
- Warning:** Only one transmitter at a time can operate on a given frequency. If you turn on your transmitter while someone else is operating a model on your frequency, both pilots will lose control of their models. Only one person can use a given frequency at a time. It does not matter if it is AM, FM or PCM—only one frequency at a time.
- Do not point the transmitter antenna directly toward the model. The radiation pattern from the tip of the antenna is inherently low.
  - Do not take chances. If at any time during flight you observe any erratic or abnormal operation, and immediately and do not resume flight until the cause of the problem has been ascertained and corrected. Safety can never be taken lightly.

### 1. Purpose

This advisory outlines safety standards for operations of model aircraft. We encourage voluntary compliance with these standards.

### 2. Background

Attention has been drawn to the increase in model aircraft operation. There is a need for added caution when operating free flight and radio controlled craft in order to avoid creating a noise nuisance or a potential hazard to full-scale aircraft and persons and/or property on the surface.

### 3. Operating Standards

Modelers generally are concerned with safety and exercise good judgment when flying model aircraft. However, in the interest of safer skies, we encourage operators of radio controlled and free flight models to comply with the following standards:

- a. Exercise vigilance in locating full-scale aircraft (get help if possible) so as not to create a collision hazard.

- b. Select an operating site at sufficient distance from populated areas so you do not create a noise problem or a potential hazard.

- c. Do not fly higher than 400 feet above the surface.

- d. Always operate more than three miles from the boundary of an airport unless you are given permission to be closer by the appropriate air traffic control facility in the case of an airport for which a control zone has been designated or by the airport manager in the case of other airports.

- e. Do not hesitate to ask for assistance in complying with these guidelines at the airport traffic control tower or air route traffic control center nearest the site of your proposed operation.

Information Provided By:

Director, Air Traffic Service Federal Aviation Administration, Washington, D.C.

---

## 13D DAILY FLIGHT CHECKS

1. Check the battery voltage on both the transmitter and the receiver battery packs. Do not fly below 9.0V on the transmitter or below 4.7V on the receiver. To do so can crash your aircraft.

**Note:** When you check these batteries, ensure that you have the polarities correct on your expanded scale voltmeter.

2. Check all hardware (linkages, screws, nuts, and bolts) prior to each day's flight. Be sure that binding does not occur and that all parts are properly secured.
3. Ensure that all surfaces are moving in the proper manner.
4. Perform a ground range check before each day's flying session. The range check should be as follows:

- Do not extend the transmitter antenna at this time. Turn the transmitter "on."
  - Turn the model "on."
  - Slowly walk away from the model while moving the control surfaces. The aircraft should function properly at a distance of 60–75 feet.
5. Prior to starting your aircraft, turn off your transmitter, then turn it back on. Do this each time you start your aircraft. If any critical switches are on without your knowledge, the transmitter alarm will warn you at this time.
  6. Check that all trim levers are in the proper location.
  7. All servo pigtails and switch harness plugs should be secured in the receiver. Make sure that the switch harness moves freely in both directions.

72 MHz requires no special license to operate.

Low Band 72 MHz		High Band 72 MHz	
Ch.No.	Frequency	Ch.No.	Frequency
11	72.010	36	72.510
12	72.030	37	72.530
13	72.050	38	72.550
14	72.070	39	72.570
15	72.090	40	72.590
16	72.110	41	72.610
17	72.130	42	72.630
18	72.150	43	72.650
19	72.170	44	72.670
20	72.190	45	72.690
21	72.210	46	72.710
22	72.230	47	72.730
23	72.250	48	72.750
24	72.270	49	72.770
25	72.290	50	72.790
26	72.310	51	72.810
27	72.330	52	72.830
28	72.350	53	72.850
29	72.370	54	72.870
30	72.390	55	72.890
31	72.410	56	72.910
32	72.430	57	72.930
33	72.450	58	72.950
34	72.470	59	72.970
35	72.490	60	72.990

**Transmitter Crystal Replacement**

**Notice:**

The Federal Communications Commission (FCC) requires that changes in transmitter frequency must be performed only

by an authorized service technician (Horizon Service Center).

Any transmitter frequency changes made by a non-certified technician may result in a violation of FCC rules.

Channels 12–14 are not available through JR®.

**Important:** Be sure to keep your original dated sales receipt, as you will be required to provide proof-of-purchase date for the equipment to be serviced under warranty.

### Warranty Coverage

Your new JR® Remote Control Radio System is warranted to the original purchaser against manufacturer defects in material and workmanship for an unprecedented 3 years from the date of purchase. During this period, Horizon Service Center will repair or replace, at our discretion, any component that is found to be factory defective at no cost to the purchaser. This warranty is limited to the original purchaser of the unit and is not transferable.

This warranty does not apply to any unit that has been improperly installed, mishandled, abused or damaged in a crash, or to any unit that has been repaired or altered by any unauthorized agencies. Under no circumstances will the buyer be entitled to consequential or incidental damages. This limited warranty gives you specific legal rights; you also have other rights, which may vary from state to state. As with all fine electronic equipment, do not subject your radio system to extreme temperatures, humidity or moisture. Do not leave it in direct sunlight for long periods of time.

### Repair Service Directions

In the event that your JR radio needs service, please follow the instructions listed below.

1. Check all on/off switches to be sure they are off. This will speed the repair process of checking battery condition.
2. Return your system components only (transmitter, receiver, servos, etc.). Do not return your system installed in a model aircraft, car, boat, etc.
3. Preferably, use the original carton/packaging (molded foam container), or equivalent, to ship your system. Do not use the system carton itself as a shipping carton, you should

package the system carton within a sturdy shipping container using additional packing material to safeguard against damage during transit. Include complete name and address information inside the carton, as well as clearly writing it on the outer label/return address area.

4. Include detailed information explaining your operation of the system and problem(s) encountered. Provide an itemized list of equipment enclosed and identify any particular area/function, which may better assist our technicians in addressing your concerns. Within your letter, advise us of the payment method you prefer to use. Horizon Service Center accepts VISA or MasterCard. Please include your card number and expiration date. Date your correspondence, and be sure your complete name and address appear on this enclosure.
5. Include your name, mailing address, and a phone number where you can be reached during the business day.

### Warranty Repairs

To receive warranty service, you must include a copy of your original dated sales receipt to verify your proof-of-purchase date. Providing that warranty conditions have been met, your radio will be repaired without charge.

### Normal Non-Warranty Repairs

Should your repair cost exceed 50% of the retail purchase cost, you will be provided with an estimate advising you of your options.

Mail your system to:

**Horizon Service Center**  
**4105 Fieldstone Road**  
**Champaign, IL 61822**  
**Phone: (217) 355-9511**





© 2003, Horizon Hobby, Inc.

4105 Fieldstone Road

Champaign, Illinois 61822

(877) 504-0233

[www.horizonhobby.com](http://www.horizonhobby.com)